



Installation & Operation Manual

NRG12-20: 12-Volt, 20-Amp Battery Charger

NRG24-20: 24-Volt, 20-Amp Battery Charger

NRG22-20: 12/24-Volt, 20-Amp Battery Charger

SENS Part Number: 101298
Document Revision: E
DCN Number: 105073
Date: January 13, 2006

Installation or service questions?
Call SENS at 1.800.742.2326 (303.678.7500)
between 8 a.m. and 5 p.m. (Mountain Time)
Monday through Friday, or visit our website.

Copyright © Stored Energy Systems LLC 2006

**SENS**[®]
Our energy means business[™]

1840 Industrial Circle
Longmont, CO 80501

Phone: 303.678.7500
800.742.2326

Fax: 303.678.7504

Email: service@sens-usa.com

Web: www.sens-usa.com

IMPORTANT SAFETY INSTRUCTIONS FOR INSTALLER AND OPERATOR

1. **SAVE THESE INSTRUCTIONS.**
2. **DO NOT EXPOSE CHARGER TO RAIN OR SNOW.**
3. Use of an attachment not recommended or sold by SENS may result in a risk of fire, electric shock, or injury to persons.
4. **ONLY TRAINED AND QUALIFIED PERSONNEL MAY INSTALL AND SERVICE THIS UNIT.**
5. Do not operate charger if it has received a sharp blow, been dropped, or otherwise damaged in any way; shut off power at the branch circuit protectors and have the unit serviced or replaced by qualified personnel.
6. To reduce risk of electric shock, disconnect the branch circuit feeding the charger before attempting any maintenance or cleaning. Turning off controls will not reduce this risk.

**WARNING:
RISK OF EXPLOSIVE
GASES.**

- A. **WORKING IN THE VICINITY OF A LEAD-ACID OR NICKEL-CADMIUM BATTERY IS DANGEROUS. STORAGE BATTERIES GENERATE EXPLOSIVE GASES DURING NORMAL BATTERY OPERATION. FOR THIS REASON, IT IS OF UTMOST IMPORTANCE THAT EACH TIME BEFORE USING YOUR CHARGER, YOU READ THIS MANUAL AND FOLLOW THE INSTRUCTIONS EXACTLY.**
 - B. To reduce the risk battery explosion, follow these instructions and those published by the battery manufacturer and the manufacturer of any equipment you intend to use in the vicinity of a battery. Review cautionary markings on these products and on the engine.
7. **PERSONAL PRECAUTIONS**
- A. Someone should be within range of your voice or close enough to come to your aid when you work near a storage battery.
 - B. Have plenty of fresh water and soap nearby in case battery electrolyte contacts skin, clothing, or eyes.
 - C. Wear complete eye protection and clothing protection. Avoid touching eyes while working near a storage battery.
 - D. If battery electrolyte contacts skin or clothing, wash immediately with soap and water. If electrolyte enters eye, immediately flood the eye with running cold water for at least 10 minutes and get medical attention immediately.
 - E. **NEVER** smoke or allow a spark or flame in vicinity of battery or engine.
 - F. Be extra cautious to reduce risk of dropping a metal tool onto battery. It might spark or short circuit battery or other electrical part that may cause explosion. Using insulated tools reduces this risk, but will not eliminate it.
 - G. Remove personal metal items such as rings, bracelets, necklaces, and watches when working with a storage battery. A storage battery can produce a short circuit current high enough to weld a ring or the like to metal, causing a severe burn.
 - H. **Use this charger for charging LEAD-ACID or LIQUID ELECTROLYTE NICKEL-CADMIUM batteries only.** Do not use this battery charger for charging dry cells, alkaline, lithium, nickel-metal-hydride, or sealed nickel-cadmium batteries that are commonly used with home appliances. These batteries may burst and cause injuries to persons and damage to property.
 - I. **NEVER** charge a frozen battery.

MODEL NUMBER CONFIGURATION

This manual contains important safety, installation and operating instructions for SENS battery charger model NRG12-20 (configured for 12V,20A only), NRG24-20 (configured for 24V, 20A only) and NRG22-20 (field configurable for 12V or 24V, 20A).

Model Number Breakout

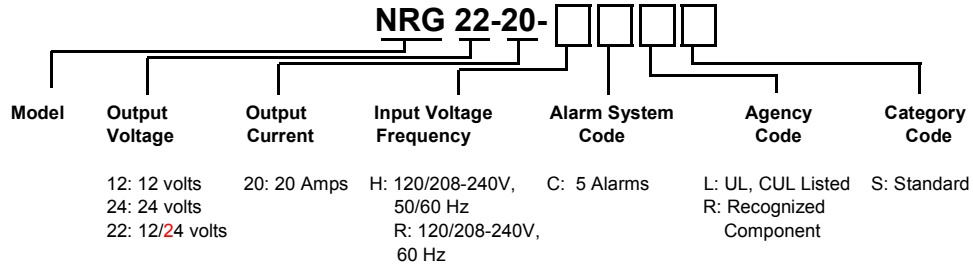

NOTE: Not all configurations are available on all models.
Contact the factory for confirmation.
**UL listed, CSA certified
*UL listed, CSA certified and CE marked

INSTALLATION INSTRUCTIONS

WARNING:
ONLY TRAINED AND QUALIFIED PERSONNEL
MAY INSTALL AND SERVICE THIS UNIT.

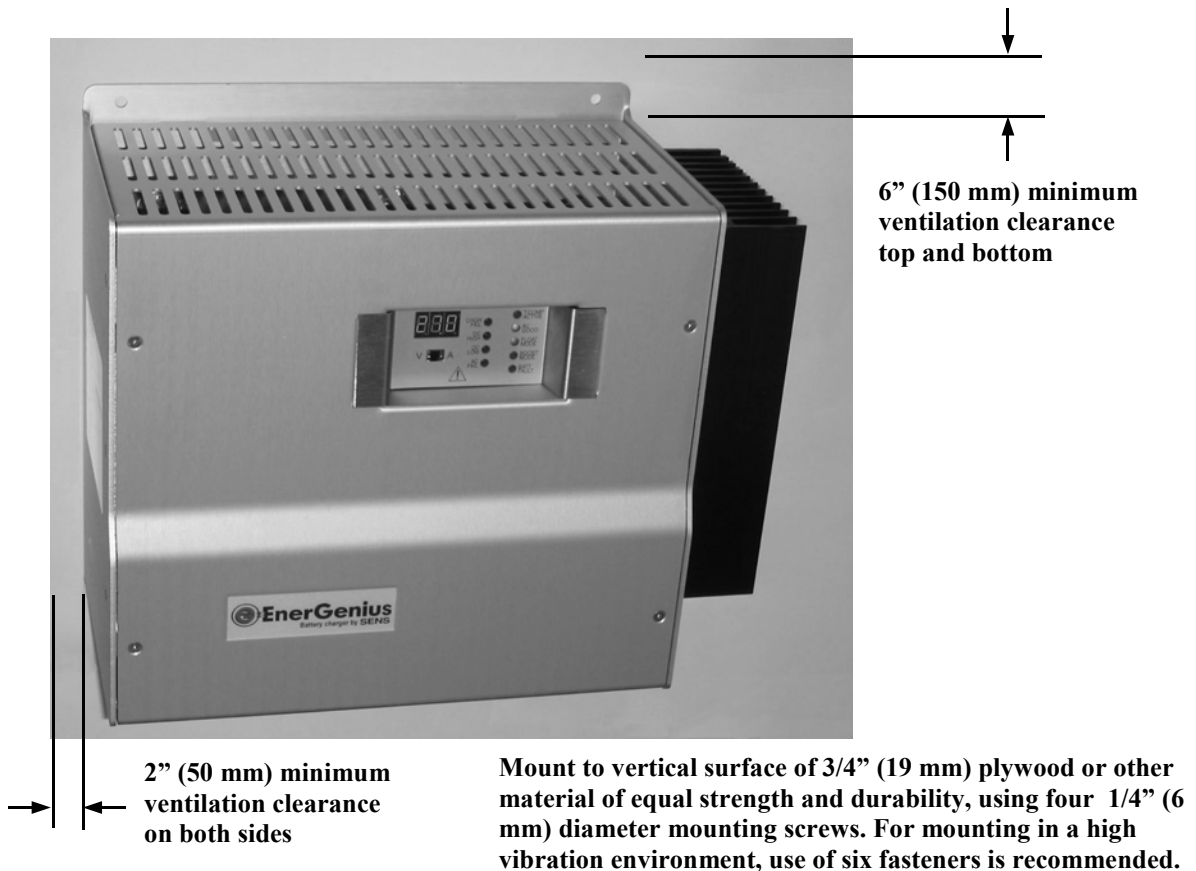

1. PREPARING FOR USE:

WARNING:
ONLY TRAINED AND QUALIFIED
PERSONNEL MAY INSTALL AND
SERVICE THIS UNIT.

- A. INSTALLATION OF THE UNIT MUST COMPLY WITH LOCAL ELECTRICAL CODES AND OTHER APPLICABLE INSTALLATION CODES.**
- B. INSTALLATION MUST BE MADE ACCORDING TO THE INSTALLATION INSTRUCTIONS AND ALL APPLICABLE SAFETY REGULATIONS.**

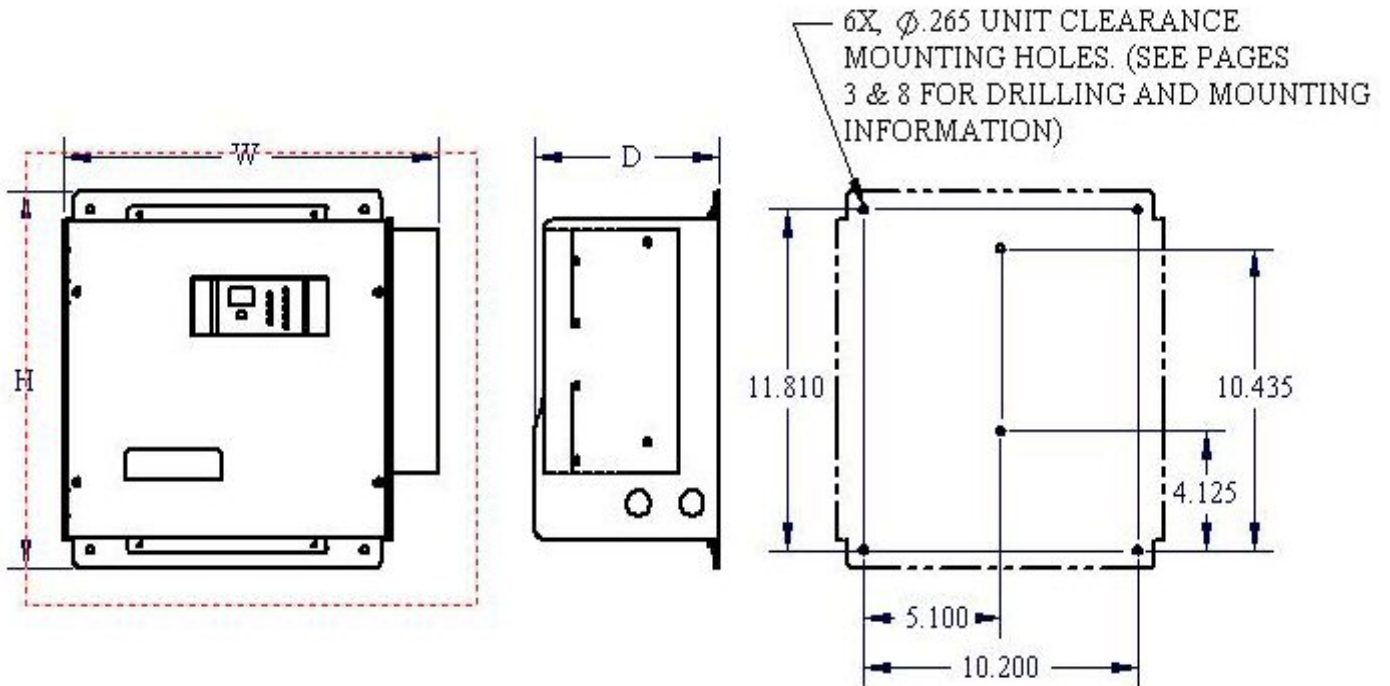

W = 13.95"
H = 13.06"
D = 6.83"

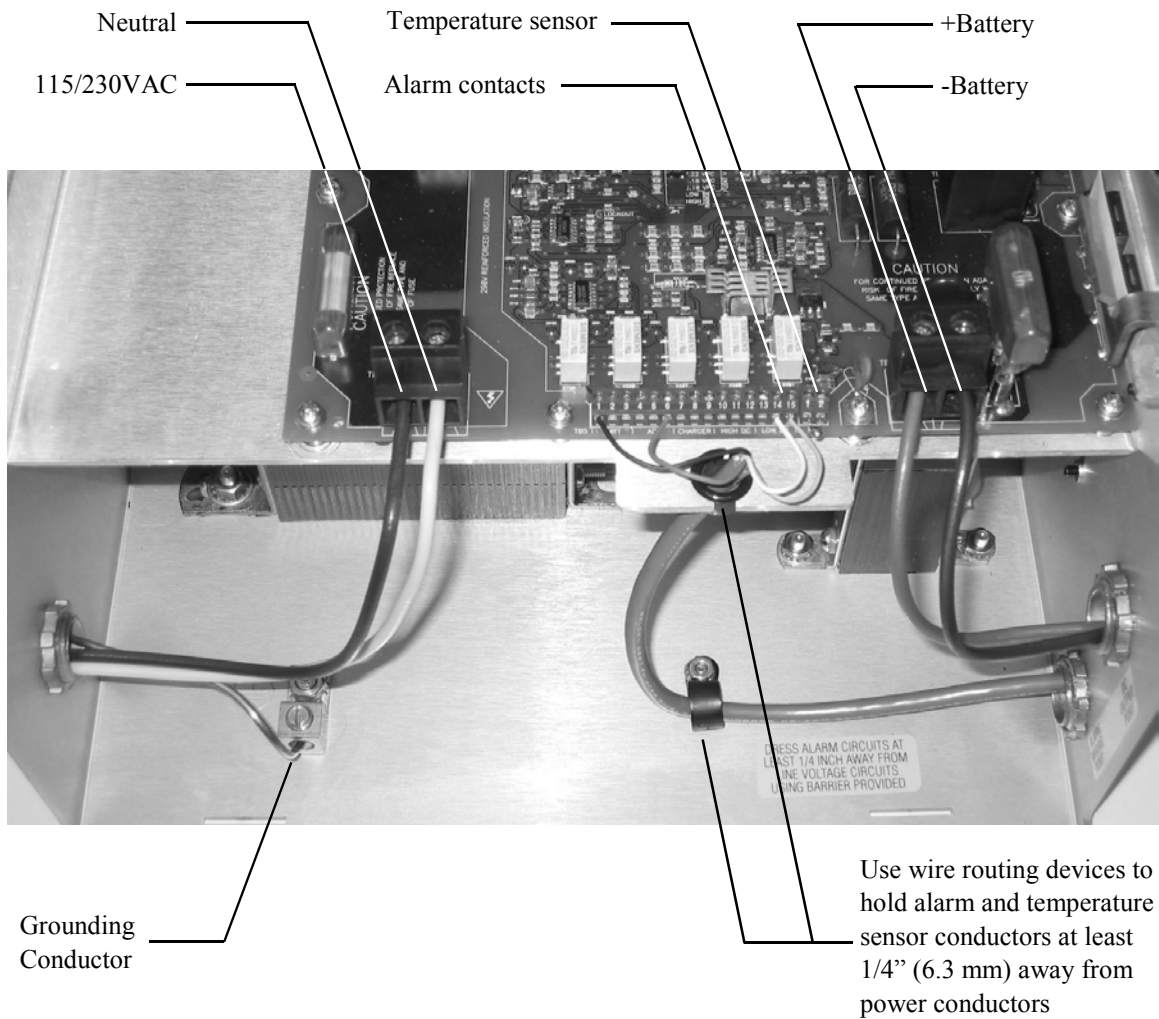

Use conductors rated 90C or higher.
Input conductors must be suitable for 15A circuits.
Battery conductors must be suitable for 40A circuits. See Section 5.
Alarm and temperature sensor may use low power conductors.

- C. This unit is permanently connected to the AC circuit and to the battery. An external disconnect device with a minimum of 0.12”(3 mm) pole separation must be located in the AC input to the charger.
- Do not energize the AC supply circuit until **ALL** wiring is connected, internal controls are properly set, and the cover is secured. Always shut the AC supply circuit off before installing or removing any wiring or opening the cover for any reason.
 - Always observe proper polarity of the DC output leads.
 - Always connect the output leads in this order: ungrounded charger output first, then ungrounded battery terminal, then grounded charger output, and grounded battery terminal last. If the battery must be disconnected for service, remove the output wiring in the reverse of the order given above.

- D. Be sure battery terminals are clean and properly tightened. Be careful to keep corrosion from coming in contact with eyes.
- E. Add distilled water to each cell until the electrolyte reaches the level specified by the battery manufacturer. This helps purge excess gas from the cells. Do not over fill. For a battery without cell caps, carefully follow the manufacturer’s recharging instructions.
- F. Study all battery manufacturer’s specific precautions such as removing or not removing cell caps while charging and recommended rates of charge.
 - The recommended charge current range must include the rated output current of this charger, which is 20 amperes.
 - Set the float voltage jumper to the battery manufacturer’s recommended float charge voltage. Incorrect charge voltage will accelerate generation of explosive gases, increasing the risk of fire or explosion.
- G. Enable the automatic boost charge mode (equalizing charge) only if recommended by the battery manufacturer
- H. Determine the voltage of the battery by referring to the engine or battery owner’s manual and make sure that the 12V/24V select jumper is set to the correct voltage.

2. CHARGER LOCATION

Do not set a battery or any other object on top of the charger. This will obstruct the ventilation openings and cause excessive heating. Ensure the charger is protected from blowing or dripping water.

3. GROUNDING INSTRUCTIONS

This battery charger should be connected to a grounded, metal, permanent wiring system; or an equipment grounding conductor (earthing conductor) should be run with the circuit conductors and connected to the equipment grounding terminal in the charger. This terminal is marked with the ground symbol. Connections to the battery charger should comply with all local codes and ordinances.

4. NEUTRAL CONNECTION

The grounded circuit conductor (neutral) should be connected to the terminal marked “N” on the input terminal block, TB1.

5. WIRE RATINGS

- A. All conductors should be rated for use at 90° C or higher.
- B. All input and output conductor sizes should be coordinated with the fault protection devices: 15A on AC input (14 AWG typical), 40A on DC output (8 AWG typical), 1 A on Alarm terminal block (20 AWG typical).
- C. *Before installation*, ensure adequate battery to charger wire gauge. Wire gauge that is too small may activate the open battery detector and the charger will shut down. The maximum allowed resistance seen by the charger is found in TABLE 1. These figures already include an allowance for charger variations (they are 80% of the typical trip-point) and are for the complete circuit: total of battery leads, battery's internal resistance, and any external equipment. The total resistance seen by the charger must not exceed the following values:

TABLE 1

	12V	24V
Maximum Resistance	36mΩ	71mΩ

D. To determine the appropriate cable and length, please refer to the following table:

TABLE 2

		Maximum Charger to Battery Distance (Ft.)		Recommended Charger to Battery Distance (Ft.)	
AWG	mΩ/Ft.	12V	24V	12V	24V
8	0.63	24	48	7	15
6	0.40	38	77	12	24

The above lengths consider the resistance of the battery and cables only and do not take into account any additional interconnects.

The above lengths are for operation at 25C. For high temperature installations (40C) reduce lengths by 10%.

In the case of high resistance in the cables to the battery the charger may cycle between AC Fail and Battery Fault LEDs (approximately every 10 seconds). Cable runs exceeding the proper length for the cable gauge used most often cause this problem. The appropriate solution is to change the cable gauge to properly correspond with the necessary cable length (see TABLE 2). In some cases where the resistance is not too far above maximum, the charger may recover after some time (approximately 10 minutes) and start charging the batteries. If it is not possible to decrease the system resistance the Battery Fault feature can be disabled. Please contact SENS at 1-800-742-2326 for further information.

- E. Refer to local electrical for additional requirements.
- F. See Section 9 for Terminal Block wire ranges.

6. MOUNTING LOCATION

- A. See the safety instructions for important information concerning the charger location.
- B. The charger should be installed in a sheltered area, protected from rain and snow.
- C. The charger should not be located where temperatures are expected to be colder than -20° C, or hotter than +40° C for operation at rated output current.

WARNING:
NEVER CHARGE STORAGE BATTERIES AT TEMPERATURES ABOVE OR BELOW THE LIMITS SPECIFIED BY THE BATTERY MANUFACTURER. NEVER ATTEMPT TO CHARGE A FROZEN BATTERY.

- D. Allow sufficient room for routing the fixed wiring to the charger. AC input enters the left side; DC output and alarms exit on the right.
- E. Leave clear space for ventilation all around the unit: at least 6 inches (15 cm) at the top and bottom; at least 2 inches (5 cm) on the sides.

- F. Charger should be mounted on a flat vertical surface so that the chassis does not warp when tightened to the wall.
- G. The charger should be mounted vertically, with the input and output terminal blocks lowermost as shown in Figure on the following page.

WARNING:
OTHER MOUNTING ORIENTATIONS INTERFERE WITH PROPER VENTILATION AND MAY CAUSE THE CHARGER TO OVERHEAT.

- H. Do not mount the charger over any heat generating equipment.
- I. Minimize vibrations that the charger will be subjected to.

7. STATIC DISCHARGE PRECAUTIONS

The printed circuit board contains static sensitive components. Damage can occur even when static levels are too low to produce a noticeable discharge shock. To avoid static discharge damage:

- A. Handle the charger by the chassis only. Remove the cover only when access is essential for installation and service, and replace it promptly when finished.
- B. If possible, wear an approved static protection strap. If one is not available, touch one hand to the chassis before contacting any other part of the charger.

8. MOUNTING PROCEDURES

WARNING:
THIS CHARGER IS INTENDED FOR COMMERCIAL AND INDUSTRIAL USE. ONLY TRAINED PERSONNEL WHO ARE QUALIFIED TO PERFORM ELECTRICAL INSTALLATIONS SHOULD INSTALL OR SERVICE THIS UNIT.

The charger mounts to a wall or other vertical support. The mounting surface must safely support the charger's weight, which is 40 pounds (18 kg), and also the weight of the fixed wiring.

*ATTENTION: FOR MOUNTING IN A HIGH VIBRATION ENVIRONMENT YOU MAY USE 6 FASTENERS AS SHOWN ON PAGE 4.

Mounting on a concrete surface:

- All mounting hardware is provided by the installer.
- Use optional ¾ in. thick, 18 in. x 24 in. sheet of marine plywood (not provided) to provide a suitable mounting surface for the charger.
- Drill four holes to secure the plywood to the wall using a minimum of four ¼ in. drive pin type expansion anchors to secure the plywood to the wall. Secure the plywood to the wall.
- Drill four (or six*) holes using the diagram on pg. 4 for ¼ (or M6) draw nut type expansion anchors through the plywood into the cement wall.
- Insert the four (or six*) draw nut type expansion anchors through the plywood into the cement wall.
- Mount charger to draw nut type expansion anchors with nuts and flat washers.

Mounting on a drywall:

- Use 3/4 in. thick plywood to span two vertical support members in the wall. The plywood sheet normally does not have to be more than 2 ft. by 2 ft. square.
- Place plywood to avoid electrical wiring, plumbing, etc., concealed behind wall.
- Secure the plywood to the vertical support members using 1/4 in. by 2 in. lag bolts and flat washers in a minimum of four places.
- Mark four (or six*) holes on the plywood using the diagram on pg. 4. Drill pilot holes into the plywood to secure the mounting bolts.
- Mount charger using four (or six*) 1/4 in. by 1/2 in. (or M6) lag bolts and flat washers.

Mounting on a metal surface:

- Mount charger using four (or six*) 1/4-20 by 3/4 in (or M6) hex head bolts, flat washers and split lock washers to attach the battery charger to a frame, panel or cross member in four (or six*) places. Use the diagram on pg. 4 to place the pilot holes, if needed.
- Tighten all bolts to recommended torque of 45-50 inch pounds.

9. **WIRING**

- A. All wiring must comply with applicable codes and local ordinances. See Section 5 for recommended gauges.
- B. The charger contains a DC output fuse for *internal* fault protection, but this will not protect the DC wiring from fault currents available *from the battery*. **CONSULT NATIONAL CODES AND LOCAL ORDINANCES TO DETERMINE IF ADDITIONAL BATTERY FAULT PROTECTION IS NECESSARY IN YOUR INSTALLATION.**

WARNING:
ENSURE THAT AC POWER IS DISCONNECTED AT THE CIRCUIT BREAKER OR OTHER SAFETY DISCONNECT BEFORE WIRING THE CHARGER.

- C. Connect the equipment grounding conductor (earthing) to the charger’s grounding terminal. This should always be the first wire connected and the last wire disconnected.
- D. Connect the DC output conductors to TB3. Make the connections in the order shown in Figure 2A (negative ground) or Figure 2B (positive ground). The terminals accept 10 through 6 AWG conductors.

CAUTION:
OBSERVE POLARITY. THE POSITIVE CHARGER OUTPUT TERMINAL IS LABELED “+” AND THE NEGATIVE TERMINAL IS LABELED “-”.

WARNING:
BE SURE TO ROUTE DC POWER WIRING AT LEAST 1/4 INCH (6.3 MM) AWAY FROM AC WIRING, ALARM WIRING, AND THE CIRCUIT BOARD.

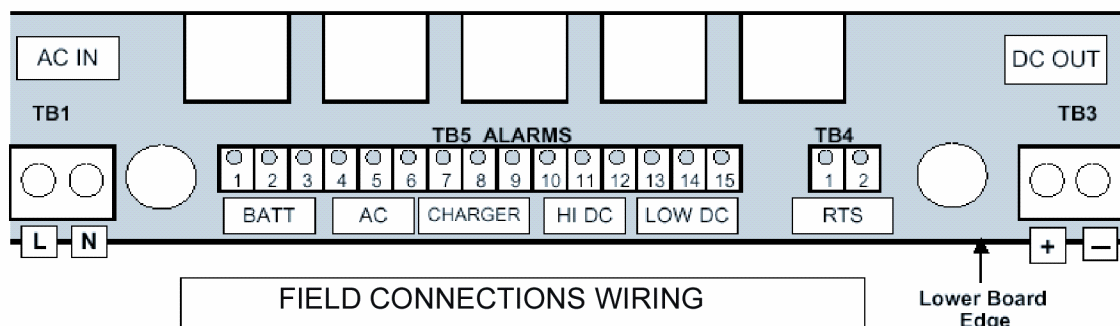

FIGURE 2A

Wiring sequence from charger to battery negative ground system

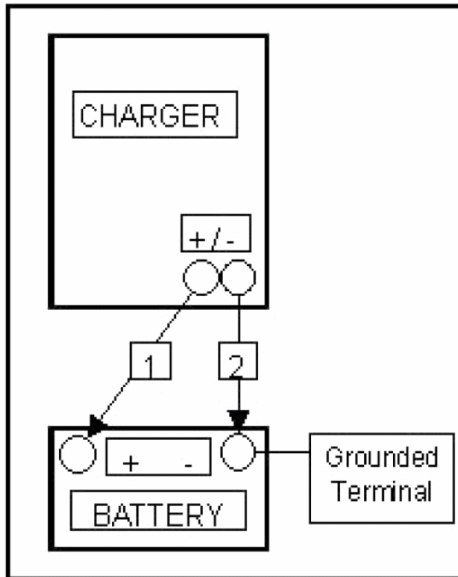
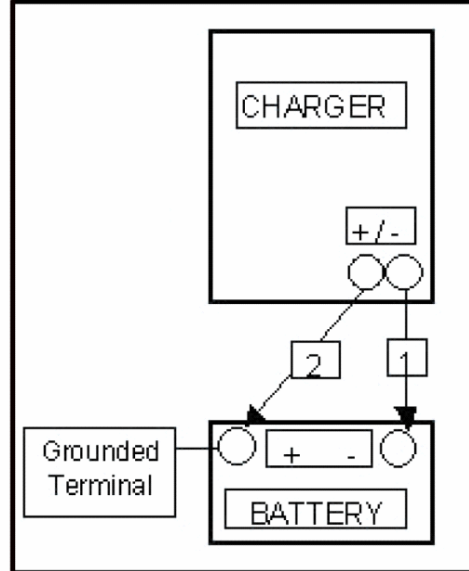

FIGURE 2B

Wiring sequence from charger to battery positive ground system



- E. Connect the AC line and neutral conductors at TB1. If there is an identified grounded circuit conductor (neutral), attach it to the terminal marked N. TB1 will accept 14-6 AWG conductors.

WARNING:

BE SURE TO ROUTE ALL AC WIRING AT LEAST ¼ INCH (6 MM) AWAY FROM DC WIRING, ALARM WIRING, AND THE CIRCUIT BOARD.

- F. If the optional alarms are used, connect the alarm wiring to their respective terminals on TB5. Route alarm wiring through the plastic bushing below TB5, keeping the conductors at least ¼ inch (6 mm) away from DC wiring, AC wiring, and the circuit board. The terminals accept 20-14 AWG conductors.

WARNING:

CONNECT ALARM TERMINALS ONLY TO LOW VOLTAGE, LIMITED ENERGY (“CLASS 2”) CIRCUITS. ALARM CIRCUITS ARE RATED 24V, 1.0A MAXIMUM.

RELAY CONTACTS	BATTERY FAIL ALARM	AC FAIL ALARM	CHARGER FAIL ALARM	HIGH BATTERY ALARM (HI DC)	LOW BATTERY ALARM (LO DC)
COMMON	TB5-1	TB5-4	TB5-7	TB5-10	TB5-13
OPEN ON ALARM	TB5-2	TB5-5	TB5-8	TB5-11	TB5-14
CLOSE ON ALARM	TB5-3	TB5-6	TB5-9	TB5-12	TB5-15

- G. If the optional remote temperature sensor is used:
 - Remove the internal sensor at TB4, if it is present.
 - Locate the remote sensor where it will accurately detect the battery temperature.
 - Connect the remote sensor leads to TB4. The sensor is not polarized, so it does not matter which lead connects to terminal #1.
 - Route sensor wiring through the plastic bushing below TB5, keeping the conductors at least ¼ inch (6 mm) away from DC wiring, AC wiring, and the circuit board.
- H. Verify that all connections are secure and in the proper locations. Tighten all unused screws on the terminal blocks to secure them against vibration.
- I. Ensure all wires are routed so the cover will not pinch them.

10. INTERNAL ADJUSTMENTS

WARNING:
MAKE SURE THE AC POWER TO THE CHARGER IS SHUT OFF WHILE MAKING THE FOLLOWING ADJUSTMENTS.

AC line voltage switch
 110-120V: Use 115V position
 208-240V: Use 230V position

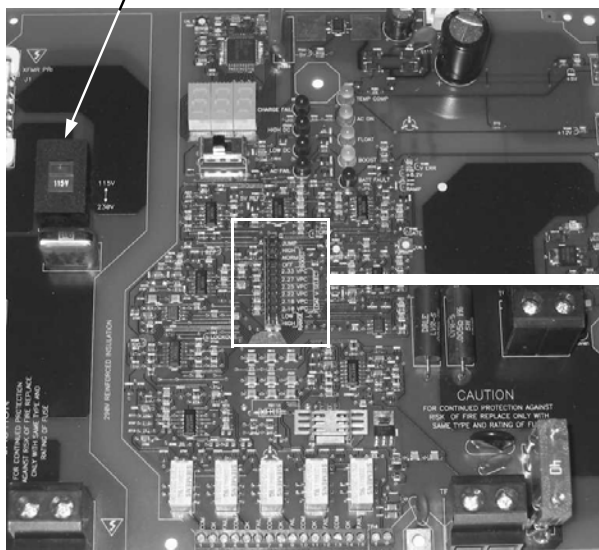

“Jump start” battery initialization mode
 Temporary use only—five minutes max!

Automatic boost jumper
 Use NORM setting for fast charge. Use Off setting for float charge only.

Float voltage jumper
 Set according to battery supplier's specifications

Battery range jumper
 (12V or 24V battery)

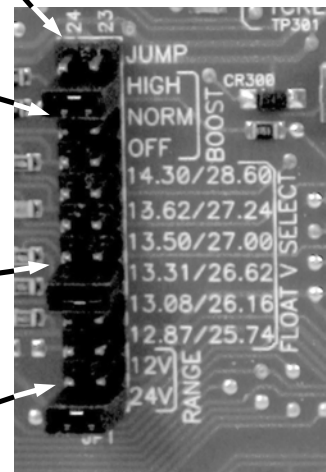

SAME FOR ALL MODELS

- A. Set the AC voltage select switch (SW100) according to the line voltage. Use the 115V position for nominal mains voltages between 110V and 120V. Use the 230V position for nominal mains voltages between 208V and 240V.
- B. Set the battery range jumper (JP1A) according to nominal battery voltage. Use the 12V position for 12V batteries. Use the 24V position for 24V batteries.
- C. Set the boost mode jumper (JP1B) according to whether the battery should have automatic boost charging. If the battery manufacturer recommends boost charging (equalization) use the NORMAL position. If not, use the OFF position.
- D. Set the float voltage select jumper (JP1C) according to the battery manufacturer's recommended 25°C float voltage. The settings are:
- 14.30/28.60 for 10 or 20 cell Nickel Cadmium at 1.43V/cell
 - 13.62/27.24 for 6 or 12 cell (VRLA) lead-acid at 2.27V/cell, and for 19 cell Nickel Cadmium at 1.43V/cell
 - 13.50/27.00 for 6 or 12 cell (VRLA or high capacity) lead-acid at 2.25V/cell, and for 19 cell Nickel Cadmium at 1.42V/cell
 - 13.31/26.62 for 6 or 12 cell (flooded) lead-acid at 2.22V/cell, and for 19 cell Nickel Cadmium at 1.40V/cell
 - 13.08/26.16 for 6 or 12 cell lead-acid at 2.18V/cell
 - 12.87/25.74 for 9 or 18 cell Nickel Cadmium at 1.43V/cell
- E. Replace the cover by sliding it straight onto the charger. Ensure the cover's locating tabs engage the slots in the chassis. Secure the cover with its four mounting screws.
- F. The JUMP position allows initial charging of Nickel Cadmium batteries, or new lead acid batteries supplied from the manufacturer dry and discharged, from a zero charge state. To use this feature, *temporarily* move JP1C from the BOOST setting to the JUMP position. Operate the charger for a short time, just long enough to retain more than 1.5V for Pb and 1.0V for NiCd per cell. Then disconnect AC power, remove the cover, and place JP1C back to desired boost setting. Replace the cover as described above.

WARNING:

USE THE JUMP FEATURE ONLY WITH LIQUID ELECTROLYTE NICKEL-CADMIUM BATTERIES, OR WITH RECENTLY FILLED NEW LEAD ACID BATTERIES SUPPLIED FROM THE MANUFACTURER DRY AND DISCHARGED. FOR EXCESSIVELY DISCHARGED LEAD ACID BATTERIES THAT HAVE ALREADY BEEN IN SERVICE, CONSULT THE BATTERY MANUFACTURER TO DETERMINE IF AND HOW THEY CAN BE SAFELY RESTORED TO SERVICE.

WARNING:

NEVER LEAVE A JUMPER IN THE JUMP POSITION DURING NORMAL OPERATION. THIS DISABLES THE BATTERY VOLTAGE INTERLOCK, WHICH INCREASES THE RISK OF ACCIDENTALLY OVERCHARGING 12V BATTERIES WITH THE 24V SETTINGS.

11. CHECK OUT

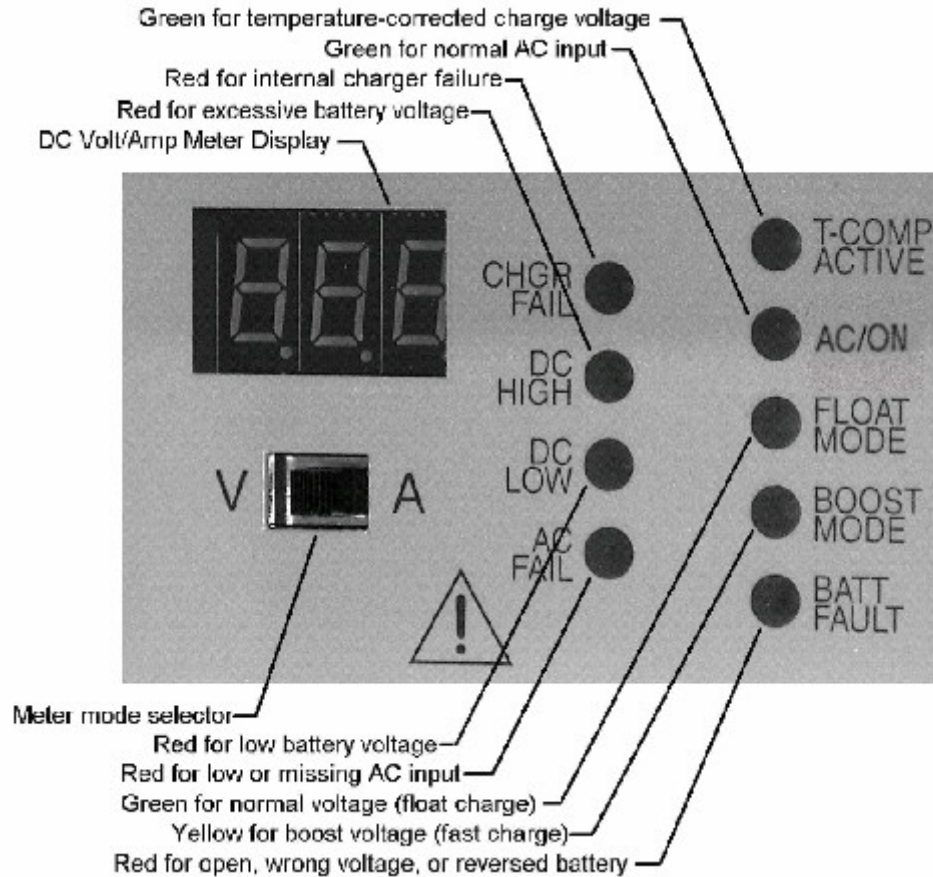
See **OPERATOR INSTRUCTION** section for LED indicator definitions:

- A. Verify the status LEDs:
 - **AC FAIL** should be **ON**. If not, the DC output may be open or reversed, or the battery may be extremely discharged.
 - **BATT FAULT** should be **OFF**. If it lights, check for reversed polarity of the DC wiring.
 - The **DC LOW** (Low Battery) LED may be either on or off, depending on the battery's state of charge.
 - All other LEDs and the meter display should be off.
 - If the **DC HIGH** LED is on, check battery voltage jumper setting.
- B. Select the voltmeter function by sliding the meter switch to the "V" position.
- C. Apply AC power by closing the branch circuit breaker and any other disconnect devices.
- D. The meter display should light immediately after power on and display the battery voltage. The green **AC/ON** LED should be lighted. If a temperature sensor is present, either internal or remote, the green **T-COMP** (Temperature Compensation) LED should be lighted.
- E. If the **BATT FAULT** LED lights when AC is applied, this indicates that the battery voltage does not agree with the **Range** jumper setting. The charger is interlocked, and will not operate in this condition. Disconnect AC power, then correct the jumper setting or battery voltage before proceeding.
- F. After a short delay (typically 10 seconds or less), the charger will produce output. The voltmeter reading should increase, indicating the battery is being charged.
- G. Change the meter switch to the "A" position to read output current.
 - Current should be close to 20A if the battery requires recharging. If automatic boost is enabled, the **BOOST MODE** LED may light, in which case the battery will be charged until it reaches 106% of the float voltage. If boost is disabled, the green **FLOAT MODE** LED should be on and the battery will charge until it reaches the float voltage setting.
 - Output current will be low if the battery is fully charged, possibly too low to read on the meter. This is normal, provided the correct charging voltage is present. The green **FLOAT MODE** LED should light when output current is below approximately 18A.

OPERATOR INSTRUCTIONS

WARNING:
NO OPERATOR SERVICEABLE PARTS INSIDE.
DO NOT OPEN.
COVER MUST BE IN PLACE DURING USE.
USE THIS CHARGER FOR CHARGING LEAD-ACID OR NICKEL-CADMIUM BATTERIES ONLY.

A. ADVANCED DESIGN FEATURES

Battery Friendly:

- Float and boost voltage selectable at install per specific battery vendor recommendations.
- Remote temperature compensation for most accurate float and boost voltage control.
- Able to charge a dead battery.
- Float and Boost voltage electronically controlled with a 4-rate fast charge program. See chart below.

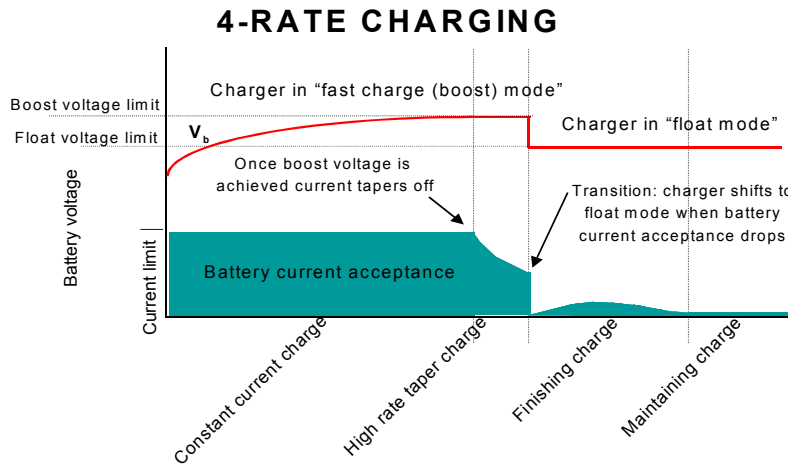

Temperature Compensation:

- The battery charger is temperature compensated to match the negative temperature coefficient of the battery. Thus, the output voltage will increase slightly as the temperature decreases and decrease as temperature increases.
- The output voltage is clamped at 0 and +40 Degrees C to protect against extremely high or low output voltage. See chart below.

AUTOMATIC TEMPERATURE COMPENSATION

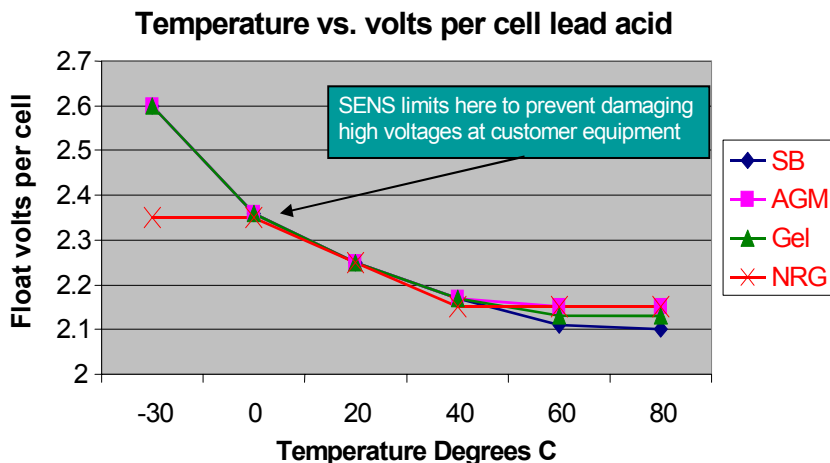

Fault Tolerant: The charger is protected from the following faults:

- Reverse battery connection.
- Powering up into a shorted battery.
- Powering up with the wrong voltage setting (24V charger with 12V battery)
- Powering up into an open battery (Battery not connected).
- Internal power component failures.
- Over heating (over temperature output power reduction).
- Protected against power line transients and surges.

Robust Hardened Construction:

- Shock and Vibration tested to UL 991, 2G.
- Shock and Vibration tested to UL 991, 5G option available.
- Lightning transient immunity to ANSI/IEEE C62.41 Cat. B and EN 50082-2 heavy industrial.
- Wide operating temperature range: -20 to + 40 Degrees C. Charger will operate at reduced output current rating up to +60 Degrees C.
- Conformal coated printed wiring boards for erosion protection.

Worldwide Agency Approvals:

- UL listed, UL 1236.
- CUL listed to CSA C22.2 107.2- M89.
- CE marked for EMC directive (industrial environment) and EN 60335-2-29.
- Worldwide operating voltage and frequency ranges.

B. FRONT PANEL LED INDICATOR DEFINITIONS AND TROUBLE SHOOTING:

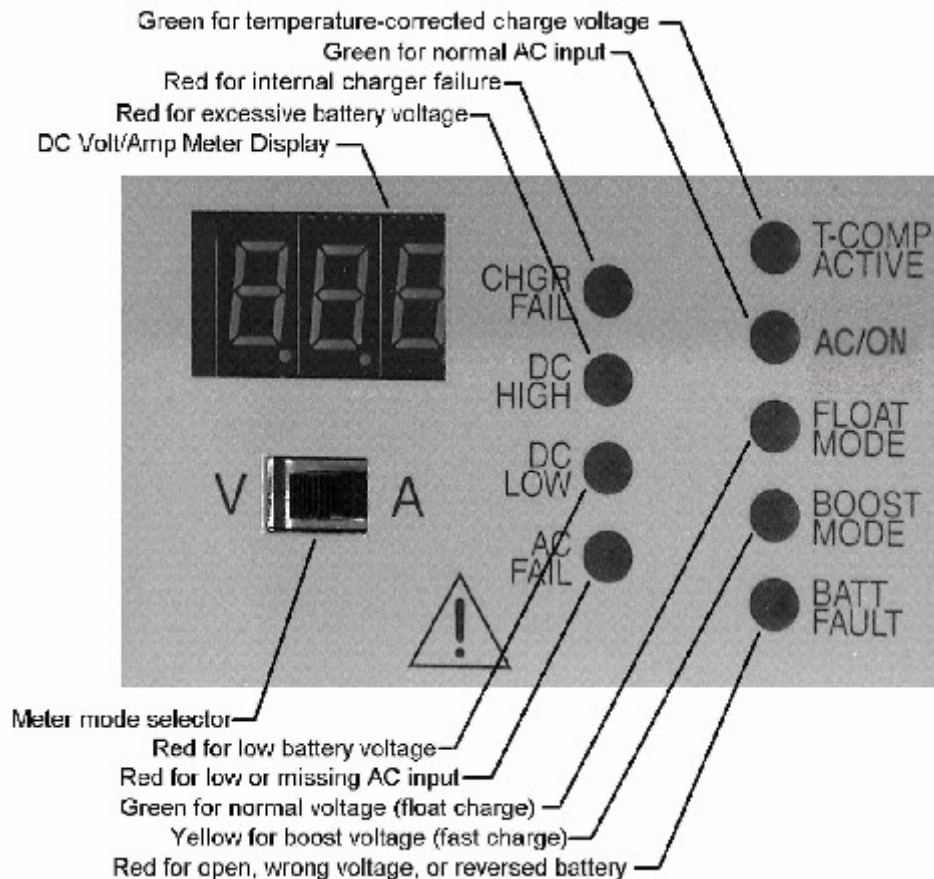

ITEM	TEXT	LED	Meaning	Troubleshooting
1	CHGR FAIL	RED	Charger Fail	Charger unable to provide charging current to battery. Replace unit. AC input voltage is too low to supply proper current when load is applied. Control board is damaged and should be replaced.
2	DC HIGH	RED	Battery DC Voltage High	Check that the battery range voltage jumper setting agrees with battery used. High battery alarm voltage is 17v for 12v system and 34v for 24v system.
3	DC LOW	RED	Battery DC Voltage Low	Check that battery range voltage jumper setting agrees with battery used. Check for defective battery. Check DC load. Low battery alarm voltage is 12v for 12v System and 24v for 24v system
4	AC FAIL	RED	Input AC Missing	Check AC input voltage to charger. Have qualified installer check AC line voltage switch setting. Setting must agree with AC voltage at site. Check AC fuse.
5	T-COMP	GREEN	On if Temperature Compensation Working, Off if Temperature Compensation Option not used.	Confirm if temperature compensation is intended to be used. Only one sensor (Local or remote) should be connected.
6	AC/ ON	GREEN	AC input good	Should be on in normal use. If LED is OFF, AC FAIL should be ON.
7	FLOAT MODE	GREEN	Charger Output in Float Mode	If the automatic boost jumper is in the OFF location, this LED will always be on. If the automatic boost jumper is in the "NORM" location, this LED will come on after the battery is nearly charged up and will stay on.
8	BOOST MODE	AMBER	Charger Output in Boost Mode	This LED will not be on if the automatic boost jumper is in the OFF location, or if the automatic boost jumper is in the "NORM" location and the battery is nearly fully charged up.
9	BATT FAULT	RED	Battery Fault-Charger automatically disabled:	<ul style="list-style-type: none"> • Battery reversed. • High resistance in charger leads (leads too small, too long , poorly connected, open). See Section 5 for information on wire length and gauge. • Battery internal open circuit. • Battery voltage does not match charger voltage range

NORMAL SET UP:

1. Elect the voltmeter function by sliding the meter switch to the “V” position.
2. Apply AC power by closing the branch circuit breaker and any other disconnect devices.
3. The meter display should light immediately after power on and display the battery voltage. The green **AC/ ON** LED should be lighted. If a temperature sensor is present, either internal or remote, the green **T-COMP** (Temperature Compensation) LED should be lighted.
4. After a short delay (typically 10 seconds or less), the charger will produce output. The voltmeter reading should increase, indicating the battery is being charged.
5. Change the meter switch to the “A” position to read output current.
 - Current should be close to 20A if the battery requires recharging. If automatic boost is enabled, the **BOOST MODE** LED may light, in which case the battery will be charged until it reaches 106% of the float voltage. If boost is disabled, the green **FLOAT MODE** LED should be on and the battery will charge until it reaches the float voltage setting.
 - Output current will be low if the battery is fully charged, possibly too low to read on the meter. This is normal, provided the correct charging voltage is present. The green **FLOAT MODE** LED should light up when output current is below approximately 18A.

C. ALARM DESCRIPTION, FIVE ALARM MODEL:

RELAY CONTACTS	BATTERY FAULT ALARM	AC FAIL ALARM	CHARGER FAIL ALARM	HIGH BATTERY ALARM (HI DC)	LOW BATTERY ALARM (LO DC)
COMMON	TB5-1 COM	TB5-4 COM	TB5-7 COM	TB5-10 COM	TB5-13 COM
OPEN ON ALARM	TB5-2 OK	TB5-5 OK	TB5-8 OK	TB5-11 OK	TB5-14 OK
CLOSE ON ALARM	TB5-3 FAIL Defaults to OK with no AC input	TB5-6 FAIL Defaults to Fail with no AC input	TB5-9 FAIL Defaults to OK with no AC input	TB5-12 FAIL Defaults to OK with no battery	TB5-15 FAIL Defaults to fail with no battery

STOP!

Verify that all settings shown below are correct *before energizing charger*. **CAUTION:** Correct settings are essential to ensure proper battery performance and long battery life. *Before installation*, ensure adequate battery to charger wire gauge. Wire gauge that is too small may activate the open battery detector and the charger will shut down:

AWG	Recommended Charger to Battery Distance (Ft.)			
	12V/10A	24V/10A	12V/20A	24V/20A
10	10	19	N/A	N/A
8	15	30	7	15
6	24	48	12	24

For runs exceeding the above values, call SENS at 1-800-742-2326 or (303) 678-7500.

FACTORY SETTINGS

Charger is factory set for the following settings. Change the setting if needed for your battery or site conditions

Input	230 VAC	
Jump:	DISABLED	
Fast charge:	ENABLED / OFF	
Float voltage	14.30	28.60
	13.62	27.24
	13.50	27.00
	13.31	26.62
	13.08	26.16
12.87	25.74	
Voltage range:	12-volt	24-volt
	12/24 dual	

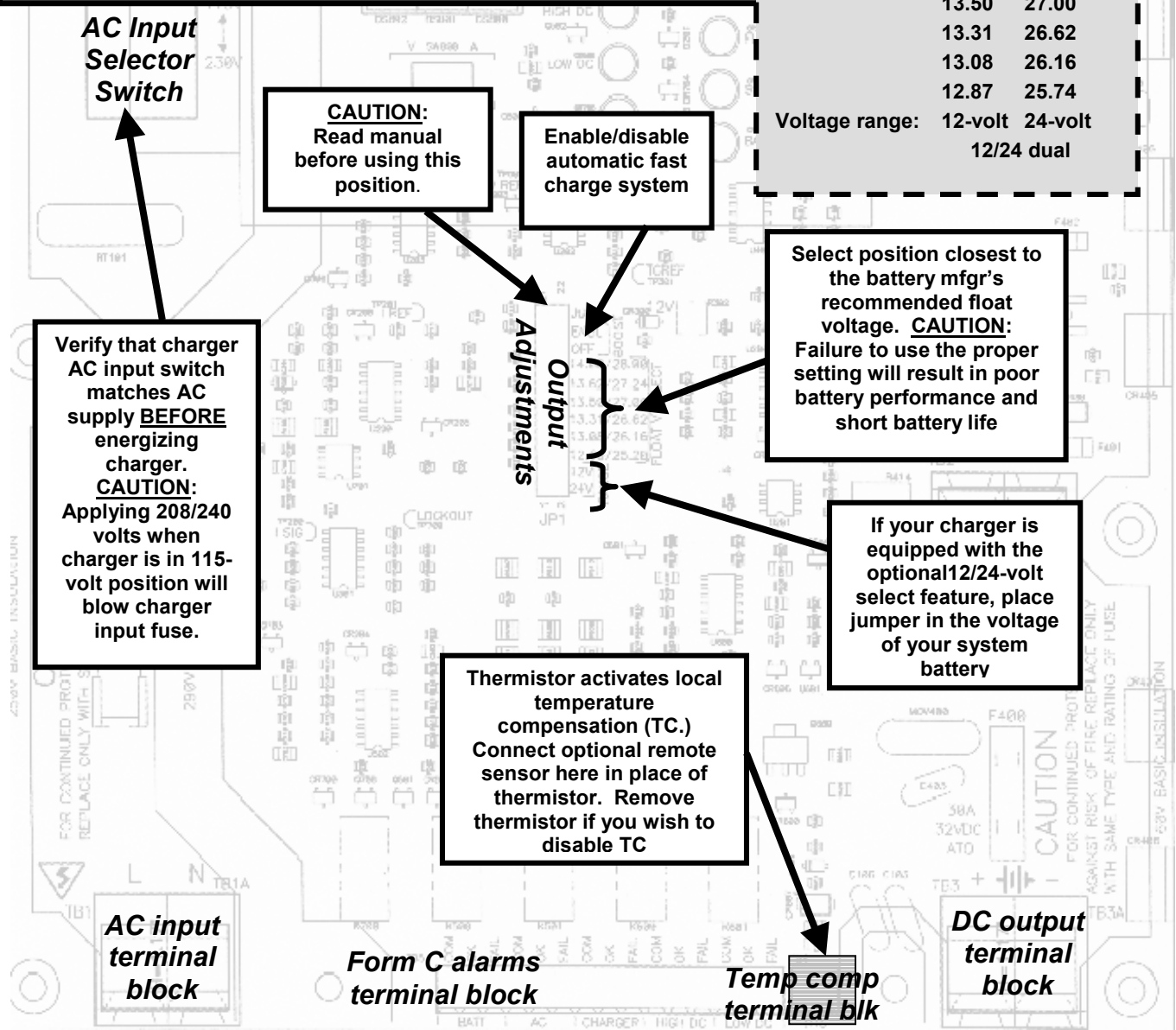

**ALL ADJUSTMENTS TO BE PERFORMED BY QUALIFIED PERSONNEL ONLY
SEE INSTALLATION MANUAL FOR DETAILS**

- | | | | |
|--------------------------------|---------------------------------------|---|----------------------------------|
| 1 With AC power to charger OFF | 2 Confirm AC safety ground is secure. | 3 Confirm AC Sel SW setting matches AC input voltage. | 4 Connect AC input wires to TB1. |
|--------------------------------|---------------------------------------|---|----------------------------------|

- | | | |
|-------------------------------|--|--|
| 5 Connect alarm wires to TB5. | 6 Connect output wires to TB3. OBSERVE POLARITY. | 7 Connect remote temp sensor to TB4 if required. |
|-------------------------------|--|--|

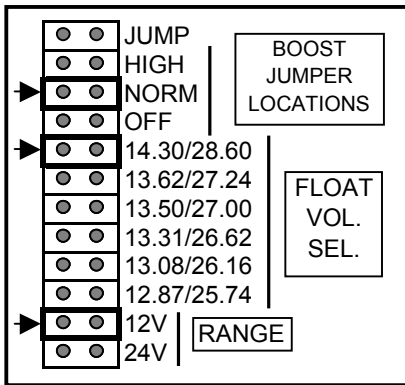
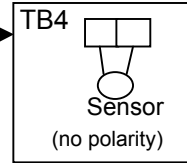

- 8 Confirm boost sel jumper is in correct position, see manual and item 12 below.

- 9 Confirm Battery Float voltage is set to match your battery type (see manual). If battery is fully charged, the voltage display will agree with this value at 25 C or when one leg of temperature sensor is removed.

- 10 Confirm that the RANGE select jumper setting matches the Battery voltage. Make no other adjustments.

- 11 Apply AC power to charger. No RED LED indicators should be on. See manual for alarm, LED display and jumper functions.

**Call 1-800-742-2326
for HELP / Or visit
www.sens-usa.com
to download manual**

- 12 Charger will not start up if dead battery voltage is less than 75% of rated voltage. In this case momentarily short JUMP pins using BOOST jumper to start a dead battery. Return jumper to original position after battery voltage comes up. Do not leave jumper in the JUMP position

4.125

5.00 max

NOTES:

1. LETTERING TO BE BLACK INK ON SILVER FOIL LABEL, MATERIAL RATED PER R/C (PGDQ2). LABEL ADHESIVE PROVIDED MUST BE SUITABLE FOR USE ON ALUMINUM & RATED FOR 80 DEG C MINIMUM.
2. PSA MATERIAL IS TO BE PROVIDED WITH RELEASE LINER.
3. RADIUS CORNERS .125" MAXIMUM.
4. THIS DRAWING NOT TO SCALE.



DCN No.	105073		
Drawn By:	KL	Date:	1/13/2006
Approved By:		Date:	
DWG Name:	LABEL, INSIDE COVER, NRG10/20		
PN: 808526	DWG REV.	C	