

Electronic Controls



Take Charge of Performance with Custom Electronic Controls.

Trombetta can customize any of its electronic controls to meet your specific requirements.

The result - you control performance with increased solenoid force capability and reduced operating temperature.

Take charge with Trombetta.

Trombetta+[®]
MOTION TECHNOLOGIES
Strokes of Genius.

Strokes of Genius

CUSTOMIZING

FEATURE ENHANCED VERSIONS AND NON-SOLENOID RELATED CONTROLS

Trombetta has the capability to design-in advanced customized features to help meet specific customer requirements. The following are a few examples of controls that Trombetta has developed for unique customer specifications.

CURRENT REGULATING OVER-ENERGIZER (CROE)

Features: Designed for mounting internally in solenoids 3 1/2" OD or larger. Voltage input 48 V AC/DC - 240 V AC/DC.

VOLTAGE CONTROL OVER-ENERGIZER (VCOE)

Features: Designed for mounting internally in solenoids to 1 3/8" OD and larger. Voltage range 8-16 VDC not polarity sensitive.

CURRENT REGULATING OVER-ENERGIZER (CROE)

Features: For dual action solenoids, controls both coils independently, two optically isolated 24 VDC signal inputs for PLC interface.

FAN REVERSING

Features: Automatically times and reverses fan. 12 VDC systems up to 25 Amp fan load.

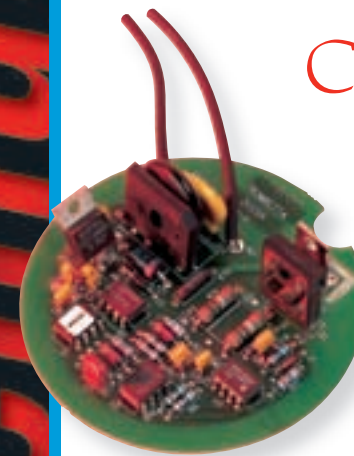

Current Regulating Over-Energizer (CROE)

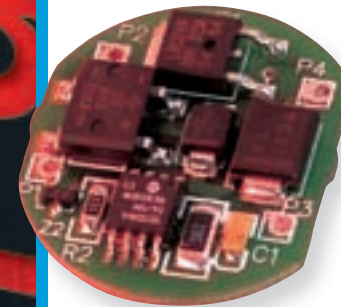

Voltage Control Over-Energizer (VCOE)

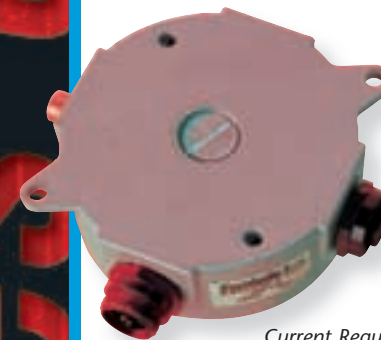

Current Regulating Over-Energizer (CROE)

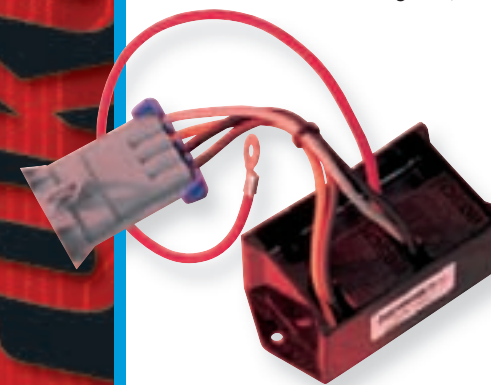

Fan Reversing

WHAT CAN WE HELP YOU TAKE CHARGE OF?

Trombetta+[®]
MOTION TECHNOLOGIES
Strokes of Genius.

13901 Main Street • Menomonee Falls, WI 53051
p 262.251.5454 • f 262.251.5757
email: sales@trombetta.com • www.trombetta.com

FUNCTIONALITY OF ELECTRONIC CONTROLS



Trombetta's selection of electronic controls.

Trombetta's Electronic Controls for solenoids regulate the magnitude of electrical drive applied to the coil during the pull-in and/or hold operation of the solenoid to optimize the performance of the solenoid. All Trombetta Controls use Pulse Width Modulation (PWM) switching to achieve high operating efficiency. Trombetta can create customized controls with enhancements to basic features to meet specific customer requirements.

By using Trombetta's Electronic Controls, customers can benefit from employing smaller solenoids than would otherwise be needed to generate the forces necessary to perform the application actuation. Smaller solenoids provide the end product designer with more mechanical design flexibility. The use of the controller maximizes the cost effectiveness of the solenoid while providing the often overlooked benefit of eliminating the need for more costly and fragile dual winding coils. A single coil under PWM control utilizes 100 percent of the winding at all times resulting in higher efficiency and cooler operation.

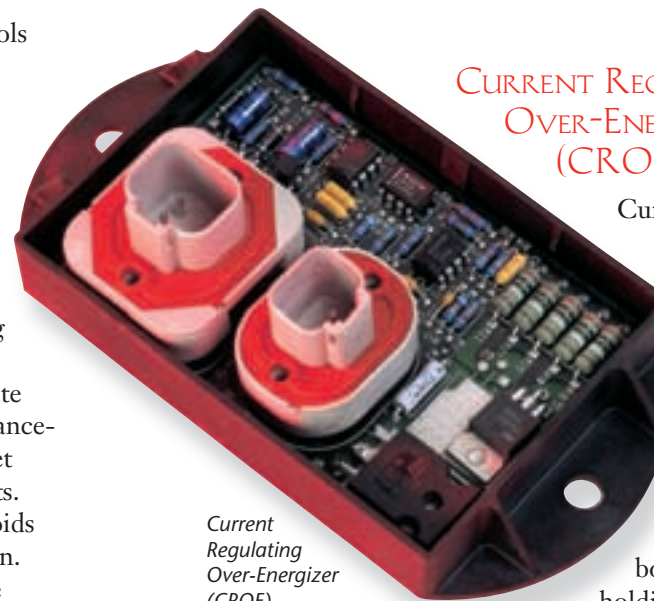

CURRENT REGULATING OVER-ENERGIZER (CROE)

Current Regulating Over-Energizer Controls exercise closed loop control over the solenoid coil. Actual coil current is sensed and regulated during both pull-in and holding modes of operation.

Current Regulating Over-Energizer (CROE)

The performance of the solenoid can be set via the specific control algorithm used in the current regulating scheme.

CROE Controls automatically compensate for significant variations in operating voltage and temperature. The end result is consistent pull/hold force under a variety of difficult operating conditions. CROE Controls allow the design to always meet minimum force requirements while eliminating the possibility of the force becoming substantially greater than required. This reduces the risk of actuator induced apparatus damage.

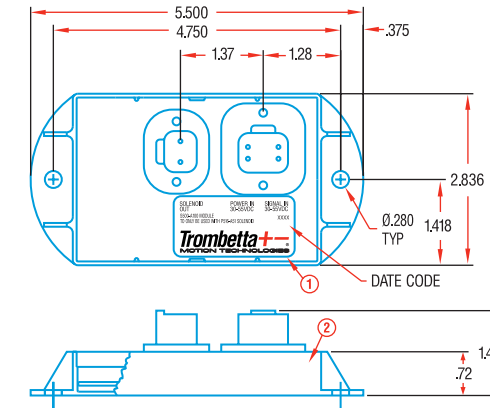

Current Regulating Over-Energizer (CROE)

Current Regulating Over-Energizer (CROE)

Voltage Input Minimum / Maximum Range	24 - 60 VDC
Pull Current (Coil)	45 Amp
Operating Ambient Temperature	-30° C to +50° C
Internal Transient Voltage Protection	5000 Watt Peak Pulse Power (10/1000 μ s) Transorb
Auxiliary Control Input Voltage Requirement	15 - 60 VDC
Auxiliary Control Current Requirement	5-35 Milliamp
Maximum Cycle Rate	2/Minute sustained for 10/minute 1 minute burst, non-repetitive
Holding Current (Coil)	4.5 Amp

TROMBETTA UTILIZES THREE SPECIFIC FORMS OF CONTROLS.

Voltage Control Over-Energizer (VCOE)

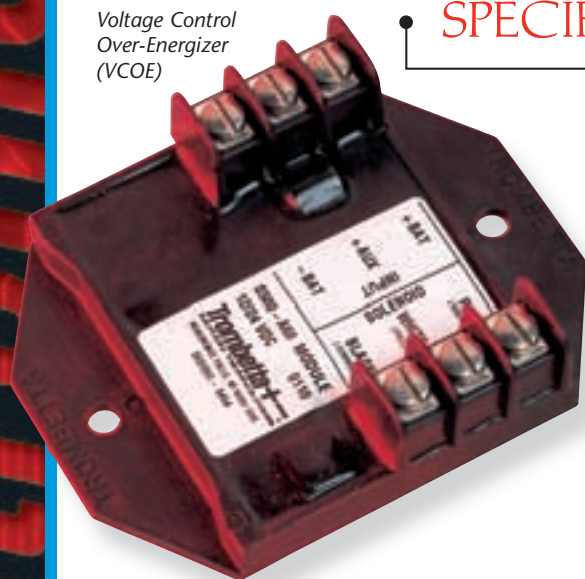

Trombetta Solenoid Controls use three methods of control. Each of the following sections provide an example of a custom control utilizing one of these methods.

VOLTAGE CONTROL OVER-ENERGIZER (VCOE)

The patented Voltage Control Over-Energizer provides open loop control of the voltage applied to the solenoid coil. No feedback is used to compensate for varied operating conditions. This type of electronic control incorporates an adjustable PWM signal to the solenoid to obtain the desired pull and hold performance.

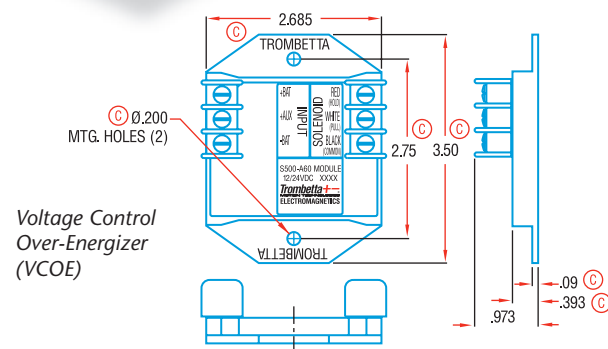

Voltage Control Over-Energizer (VCOE)

Voltage Control Over-Energizer (VCOE)

Voltage Input Minimum / Maximum Range	8.5 - 32 VDC
Maximum Load Current	80 Amp
Operating Ambient Temperature	-30° C to +80° C
Transient Voltage Protection	Integral 5000 Watt Peak Pulse Power TVS
Auxiliary Control Input Voltage Requirement	8.5 - 32 VDC
Auxiliary Control Current Requirement	Less than 50 Milliamp
Maximum Cycle Rate	6 Cycles/Minute for 1 minute maximum duration

FORCE REGULATING OVER-ENERGIZER (FROE)

Force Regulating Controls are designed specifically for Trombetta HF, High Force Solenoids. FROE Controls use proven Trombetta proprietary technology that is customized to application specifications. FROE Controls regulate the force of the stroke to provide nearly identical forces from the beginning to the end of the solenoid stroke. FROE Controls compensate for external factors of voltage and temperature changes and add closed loop control compensation for plunger positioning that allows the maintaining of the near constant force throughout the working stroke. FROE Control designs require very complete application requirement specifications and should be developed in conjunction with the solenoid to assure proper operation.

FOR MORE INFORMATION, VISIT OUR WEBSITE AT WWW.TROMBETTA.COM.

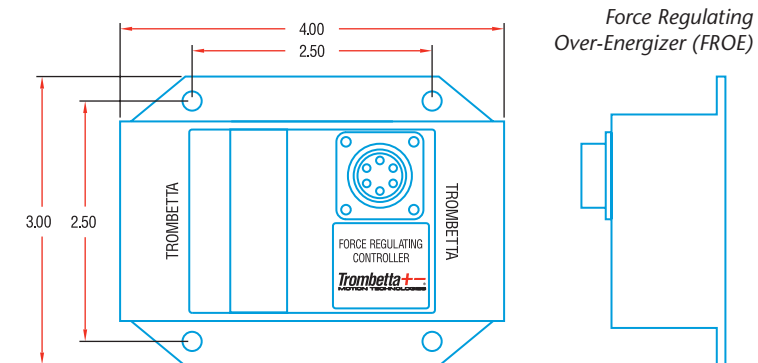

Force Regulating Over-Energizer (FROE)

Force Regulating Over-Energizer (FROE)

Voltage Input Minimum / Maximum Range	100 - 140 VAC
Maximum Load Current	25 Amp
Operating Ambient Temperature	-20° C to 50° C
Control Input Voltage Requirement	24 VDC (On/Off) 0-5 VDC (Proportional)
Auxiliary Control Current Requirement	10 Milliamp Maximum
Maximum Cycle Rate	30 Cycles/Minute