

A LARGER SOLENOID IN TROMBETTA'S RELIABLE 600 SERIES, THE P/Q613 PACKS A PUNCH

P/Q613 Features

Trombetta's larger, more powerful P/Q613 solenoid features dual coil design and a longer stroke for maximum performance.

- Heavy duty performance with a longer stroke.
- State of the art construction for problem-free operation... "3-wire" design for reliability.
- High pull-in force and continuous duty operation.
- No "mechanical" or "integral" switch problems.
- Misadjustment will not cause burn-out.
- Ideal for "on-to-run/fuel shut-down" applications.
- Easily replaces most competitive solenoids.
- Many options available: hoot is standard.

P/Q613 Applications

Trombetta's powerful P/Q613 solenoids provide maximum "pull" or "push" performance for engine speed control, diesel engine shutdown, and a variety of heavy duty industrial applications where a high power solenoid is a requirement.

P/Q613 General Specifications

RATED VOLTAGE	12 VOLT	24 VOLT
PULL CURRENT	70 AMPS	36 AMPS
HOLD CURRENT	.88 AMPS	.48 AMPS
PULL FORCE @ 1 1/2"	21 POUNDS (94 NEWTONS)	21 POUNDS (94 NEWTONS)
HOLD FORCE AT RATED VOLTAGE AND 25°C.	40 POUNDS (178 NEWTONS)	40 POUNDS (178 NEWTONS)
SHIPPING WEIGHT	2.7 POUNDS	2.7 POUNDS

P/Q613 "3-Wire" Solenoid System Operation

The Trombetta P/Q613 Solenoid Series is a state-of-the-art design for demanding engine applications. Dual coil construction delivers high pull-in force and continuous duty hold operation in a compact package. The "3-Wire" solenoid system is highly reliable and puts an end to "mechanical switch" problems. Two systems are available for your specific application. Proper installation of either system will eliminate the possibility of solenoid burn out. Fouled or misadjusted linkage will result in the solenoid only dropping out, not burning out.

- System #1 - Typically used for "on-to-run" engine shut down applications.

Operation: The solenoid is wired directly into the existing engine starter system eliminating the need for "internal" solenoid switches. At the engine starting phase, both coils are energized for the highest possible

pull-in force. After the engine is started, the pull-in coil is de-energized, while the hold coil remains energized providing continuous duty operation.

- System #2 - Typically used for "RPM/Speed Control" applications.

Operation: On applications other than "on-to-run/fuel shut down" applications, a Trombetta S500 Series Electronic Control module is required to allow the solenoid to operate in a continuous duty mode. (See back-page for complete S500 module information.) This remotely mounted electronic switching module will, when energized, power both the pull-in and hold-in coils long enough for the plunger to pull-in and hold. As the module "times out" the pull-in coil is disconnected, putting the solenoid in the "hold-in" mode.

Trombetta 
MOTION TECHNOLOGIES

Trombetta
P/Q613 SERIES
Solenoids



Trombetta solenoid products have been designed and manufactured in the U.S.A. since 1932.

See Trombetta first for long-lasting tough-duty solenoids to fit the toughest - or easiest - applications.

13901 Main Street
Menomonee Falls, WI 53051
(262) 251-5454 Ext. 2440
FAX: (262) 251-5757
www.trombetta.com

Trombetta P/Q613 SERIES Solenoids



Determining Solenoid Performance

When a solenoid is used in the continuous hold position, the coil temperature rises. The following steps will allow you to find the pull and hold force available at the elevated coil temperatures seen in this situation. K Factor is a derating constant used to find the pull and hold forces at elevated temperatures. The nominal K Factor is 1.0.

- Step 1. Use the Final Coil Temperature chart to find coil temperature using ambient temperature and applied voltage.
- Step 2. Use the Normalized K Factor chart to find normalized K Factor using the temperature found in Step 1 and the voltage applied to the coil. The Normalized K Factor can be read on the left of the chart.
- Step 3. Use the Pull Force vs. Stroke chart to find pounds of pull force available using the Normalized K Factor found in Step 2, and the stroke in inches.
- Step 4. Use the Hold Force chart to find hold force available using the Normalized K Factor found in Step 2.

For an application other than described above, consult Trombetta Corporation.

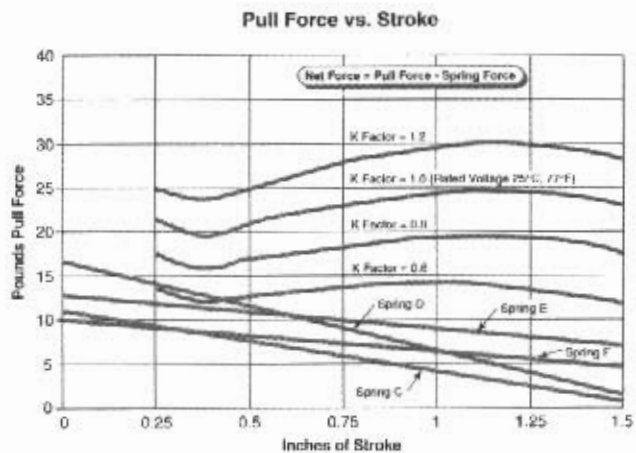
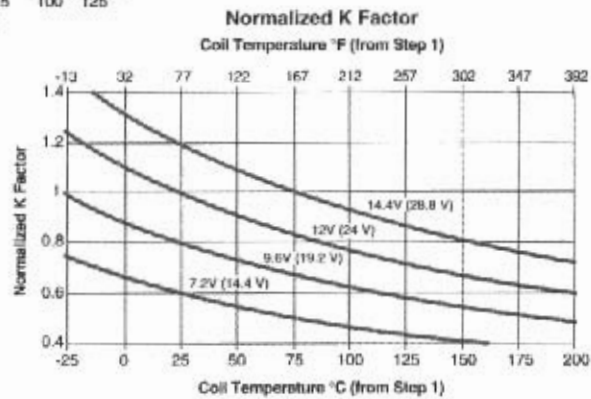
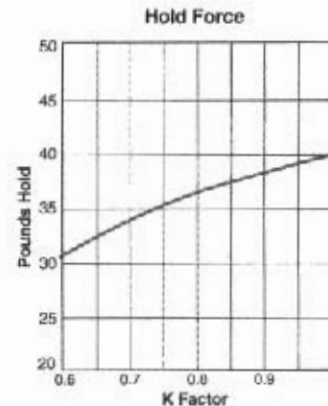
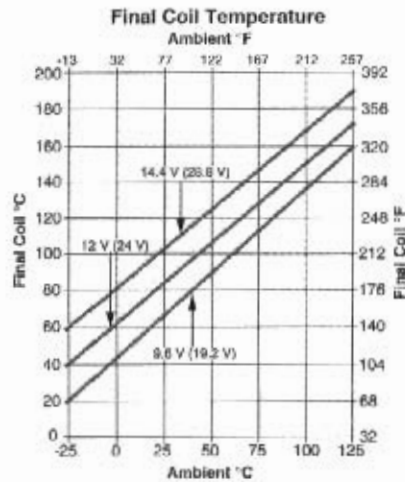

P/Q613 Solenoid Series... (all dimensions in inches and millimeters)

FLANGE MOUNT ("P" Model - Pull Type)

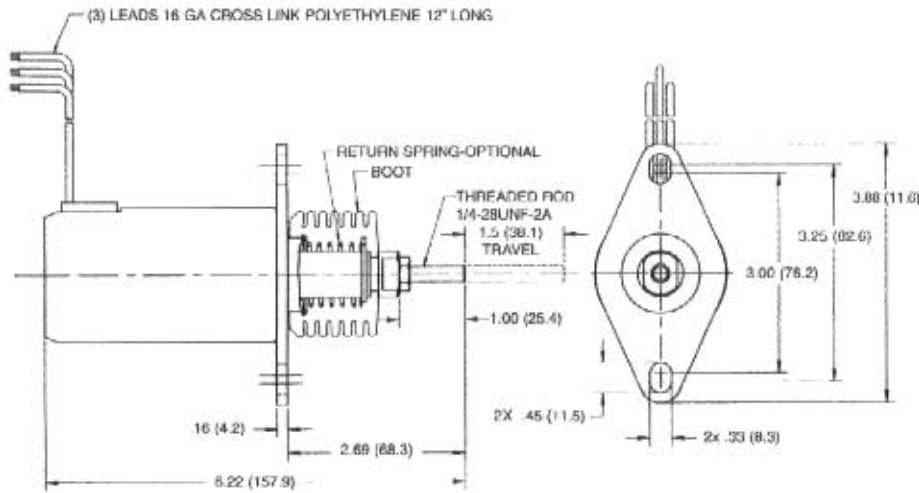

SIDE MOUNT ("P" Model - Pull Type)

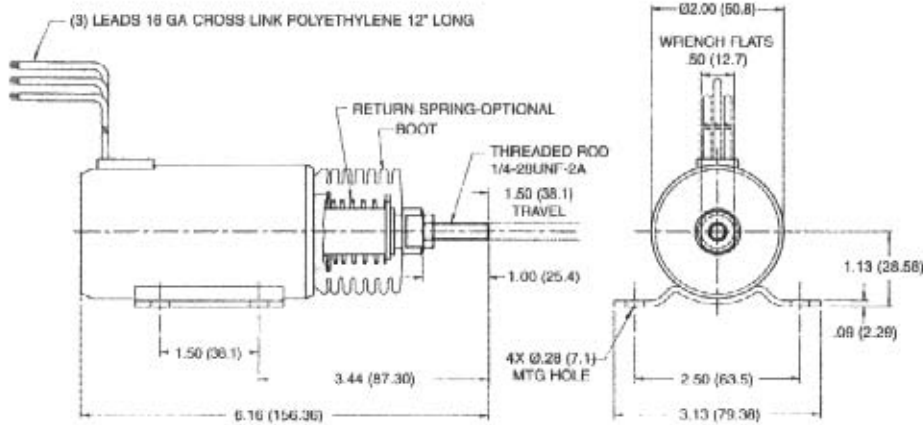

SIDE MOUNT ("Q" Model - Push Type)

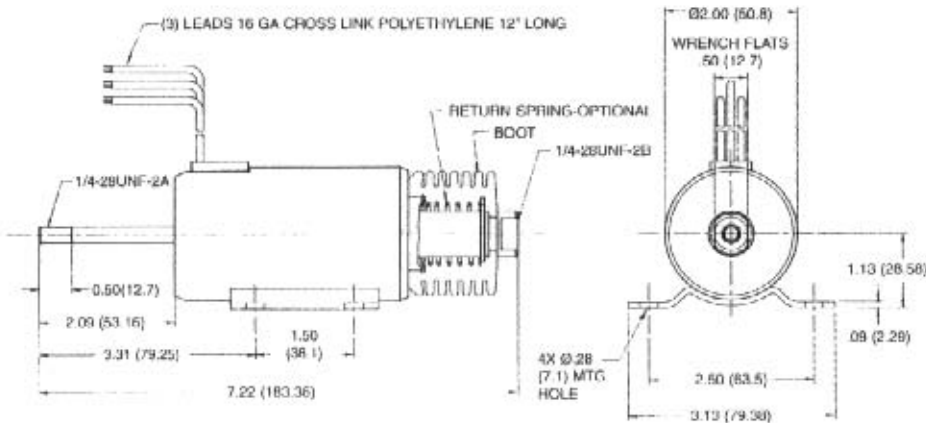

Trombetta
P/Q613 SERIES
Solenoids



Trombetta 
MOTION TECHNOLOGIES

Trombetta S500 Series Solenoid Control Modules ... for use in continuous duty mode.

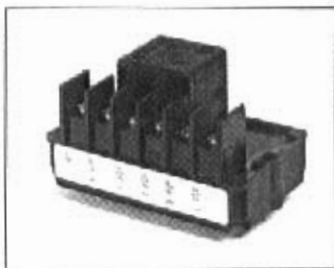

Trombetta's S500 Series Solenoid Control Modules are rugged, field proven devices which function as remotely operable, high current timing/switching controls for operating 3-wire solenoids in 2-wire systems. When utilized with Trombetta's proven 3-wire solenoids, they provide a system that can upgrade applications that previously required internally switched solenoids and/or elaborate wiring methods requiring additional costly relays/contactors. Trombetta's S500 series modules allow you to achieve today's 3-wire reliability and simplicity in yesterday's 2-wire systems. Ideal for throttle controls... ideal for remote operation requirements because they require light gage (only 1 amp capacity!) wiring to the remote control location.

Operation

Using the Trombetta S500 Series Electronic Control module allows all models of the P/Q600 Series solenoids to be operated as "continuous duty" devices, when applied to applications other than "on-to-run/fuel shut off". When 12 or 24 VDC is applied to the module, it will supply power to both the solenoid "pull-in" and "hold-in" coils simultaneously, causing the solenoid to pull in and hold. After approximately 1/2 second, the module timer/relay automatically removes voltage from the high current "pull-in" coil and leaves only the "hold-in" coil energized. The solenoid will remain in the hold mode until power is removed from the S500 module. When input voltage is re-applied, the module cycles through the "pull-in" mode again. For detailed specifications, request bulletin X232.

P/Q613 Series Part Numbers

MODEL	MOUNT		TYPE		RETURN SPRING/FORCE (LB)		MAX STROKE INCHES
	SIDE	FLANGE	PULL	PUSH	ENERGIZED	@MAX STROKE	
P613-A1V*	X		X		NONE	NONE	1.5
P613-C1V*	X		X		F10124/11.2	F10124/1.0	1.5
P613-D1V*	X		X		F09515/16.9	F09515/1.5	1.5
P613-E1V*	X		X		H10101/13.2	H10101/7.0	1.5
P613-F1V*	X		X		F10399/10.5	F10399/4.6	1.5
P613-A5V*		X	X		NONE	NONE	1.5
P613-C5V*		X	X		F10124/11.2	F10124/1.0	1.5
P613-D5V*		X	X		F09515/16.9	F09515/1.5	1.5
P613-E5V*		X	X		H10101/13.2	H10101/7.0	1.5
P613-F5V*		X	X		F10399/10.5	F10399/4.6	1.5
Q613-A1V*	X			X	NONE	NONE	1.5
Q613-C1V*	X			X	F10124/11.2	F10124/1.0	1.5
Q613-D1V*	X			X	F09515/16.9	F09515/1.5	1.5
Q613-E1V*	X			X	H10101/13.2	H10101/7.0	1.5
Q613-F1V*	X			X	F10399/10.5	F10399/4.6	1.5

- * Insert "13" for 12 Volt, and "24" for 24 Volt
- Pull plunger thread - 1/4-28 rod, removable for internal threads
- Other options available

Trombetta... Specializing In Innovative Solutions For Your Electromagnetic Needs

See Trombetta first for a wide variety of ultra-reliable push-or-pull solenoids, electronic control modules, throttle control kits and solenoid linkage accessories.

As a leading supplier to industry for over 60 years, Trombetta offers design and application expertise for standard or custom solenoid products for hundreds of applications. Here are just a few:

- Automotive Industry
- Diesel Engines
- Transportation
- Packaging Machinery
- Factory Automation
- Material Handling
- Food Processing
- Medical Equipment
- Automation Systems
- Security Systems
- Construction Equipment
- Agriculture Equipment
- Military Defense Equipment
- Electrical Switchgear
- Marine Equipment

Trombetta 
MOTION TECHNOLOGIES

Trombetta P/Q613 SERIES Solenoids

P/Q613 Series Options

- Custom return springs
- Electrical connectors
- Additional voltages
- Custom designs available

Trombetta solenoid products have been designed and manufactured in the U.S.A. since 1932.

See Trombetta first for long-lasting tough-duty solenoids to fit the toughest - or easiest - applications.

13901 Main Street
Menomonee Falls, WI 53051
(262) 251-5454 Ext. 2440
FAX: (262) 251-5757
www.trombetta.com

TROMBETTA'S 2-POSITION ELECTRIC THROTTLE CONTROL KIT* MOUNTS ANYWHERE

P613-K Features

Designed for the ultimate in reliability, Trombetta's remote-mount engine throttle control kit combines 3-wire concept with innovative electronic/mechanical technology.

RELIABLE

- Solenoids will not burn out if cable is misadjusted.
- Solenoid and module can be mounted away from engine heat and vibration.
- The kits are self-contained.

SAVES MONEY

- Significantly reduces installation and adjustment time.
- Reduces warranty claims.

VERSATILE

- Fits a majority of engine types.
- Adjustable stroke from 3/8" to 1 1/2" and 30 pounds of force.
- Easy to mount in crowded engine compartments.
- Includes cable shortening feature.

REMOTE CONTROL

- Control circuit draws low current allowing greater distances between the operator and the engine.
- Can be controlled with a variety of switching devices.
- Immune from electrical system noise.
- Reverse polarity protected.

EASY TO INSTALL

- Comes fully assembled.
- Very few steps and simple to adjust.
- Less expensive than most alternatives.

SALES AND SERVICE SUPPORT

- Rapid delivery from stock.
- Experienced technical assistance.

P613-K Applications

Trombetta's throttle kit provides "on demand" throttle control for air compressors, utility trucks, stationary generators/welders, emergency vehicles, maintenance and construction equipment.

P613-K General Specifications

RATED VOLTAGE	12 VDC	24 VDC
PULL-IN CURRENT	70.5 AMPS	36.4 AMPS
HOLD-IN CURRENT	0.9 AMPS	0.5 AMPS
PULL-IN FORCE (AT 68° F [20° C])	20 LB. (89 NEWTONS)	20 LB. (89 NEWTONS)
HOLD-IN FORCE (AT 68° F [20° C])	40 LB. (178 NEWTONS)	40 LB. (178 NEWTONS)
MAXIMUM AMBIENT TEMPERATURE	257° F (125° C)	257° F (125° C)
MAXIMUM COIL TEMPERATURE	380° F (193° C)	380° F (193° C)
MAXIMUM SOLENOID CYCLE RATE	6/MIN.	6/MIN.

P613-K System Operation

Trombetta's P613-K1 throttle control solenoid kit consists of a "three-wire", dual coil solenoid, electro-mechanical control module and stainless steel sheathed pull cable. The sheathed pull cable allows the solenoid to be mounted away from hostile environments, such as engine vibration and high temperature.

The throttle solenoid can be activated automatically or "on demand" to bring the idle speed to a pre-set high idle position.

The control module allows the solenoid to operate as a continuous duty device. When the module is wired as recommended, applying 12 VDC to the "AUX" terminal applies voltage to the hold-in and pull-in coil of the solenoid. After 0.5 to 0.75 seconds, power is automatically removed from the pull in coil. Power will remain at the hold-in coil until the 12 VDC signal is removed from the "AUX" terminal.

*Patented

Trombetta + —
ELECTROMAGNETICS

Trombetta P613-K SERIES Throttle Control Kit



13901 Main Street
Menomonee Falls, WI 53051
(414) 251-5454
FAX: (414) 251-5757
<http://www.trombetta.com>

P613-K Dimensions and Wiring Configurations

(All dimensions in inches and millimeters)

General Component Dimensions

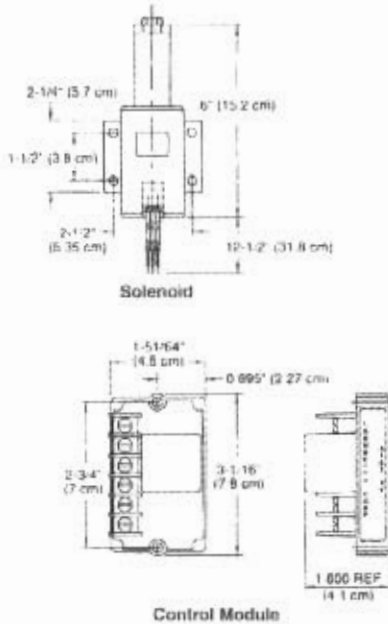

Wiring Configuration 12 VDC Application

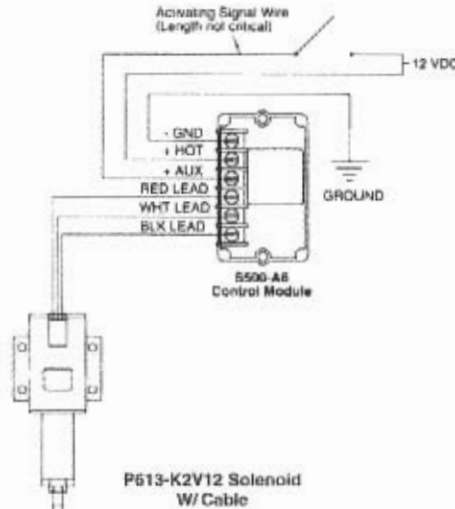

Wiring Configuration 24 VDC Application

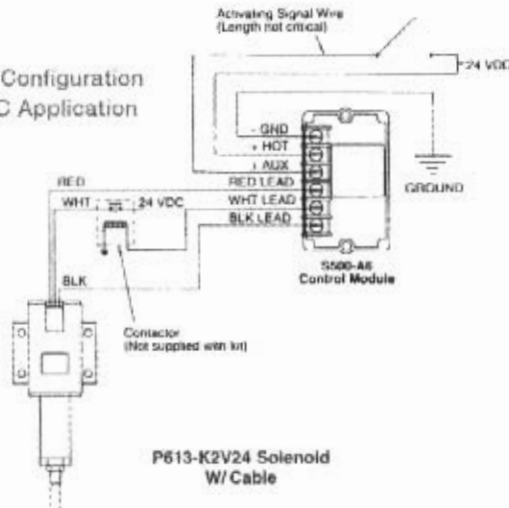

Trombetta P613-K SERIES Throttle Control Kit

P613 Standard Kit Part Numbers

Kit Part Number	Volts
P613-K1V12	12
P613-K1V24	24

• Additional models available

P613-K Series Options

Trombetta P613 K throttle control kits offer a variety of options for customized installations.

- Electrical Connectors
- Custom Modification

Trombetta solenoid products have been designed and manufactured in the U.S.A. since 1932.

See Trombetta first for long-lasting tough-duty solenoids to fit the toughest – or easiest – applications.

Trombetta 
ELECTROMAGNETICS

13901 Main Street
Menomonee Falls, WI 53051
(414) 251-5454
FAX: (414) 251-5757
<http://www.trombetta.com>

P613-K Series Parts List

ITEM	P/N	DESCRIPTION
1	E07195	CABLE PIVOT 1/8" THICK*
2	H10407	COTTER PIN
3	NA	CABLE BULKHEAD
4	E07046-1	CABLE BRACKET
5	SPECIFY KIT#	CABLE ASSEMBLY 46" LONG**
6	NA	JAM NUT
7	NA	ALUMINUM ADJUSTMENT NUT
8	P613-K2V12	SOLENOID ASSEMBLY W/CABLE (12 VDC)
8	P613-K2V24	SOLENOID ASSEMBLY W/CABLE (24 VDC)
9	S500-A6	CONTROL MODULE

* OTHER PIVOT OPTIONS AVAILABLE

** CABLE SHORTENING FEATURE INCLUDED

