

NOTES:

- MATERIAL : CRS, .063 INCH THICK, (16 GAUGE).
FINISH: POWDER COAT CARDINAL #F141B03, MASK THREADS.
- METAL STAMP OR MARK WITH EPOXY INF. PART NUMBER, REVISION, (XX=REV) AND TEXT .12 HIGH MIN. APPROXIMATELY WHERE SHOWN.
- THE FINISHED PART AS DELIVERED TO SENS MUST BE COMPLIANT WITH THE EUROPEAN UNION DIRECTIVE ON THE RESTRICTION OF THE USE OF CERTAIN HAZARDOUS SUBSTANCES IN ELECTRICAL AND ELECTRONIC EQUIPMENT (ROHS). A CERTIFICATE OF COMPLIANCE MUST BE PROVIDED AND MUST CONTAIN THE FOLLOWING MINIMUM INFORMATION: DATE OF ISSUANCE, MANUFACTURER'S COMPLETE NAME AND ADDRESS, UNIQUE PART NUMBER(S) AND REVISION(S) FOR EACH PART, AND PRINTED NAME/TITLE/SIGNATURE OF AN AUTHORIZED REPRESENTATIVE OF THE MANUFACTURER.

NOTE 2
THIS SIDE

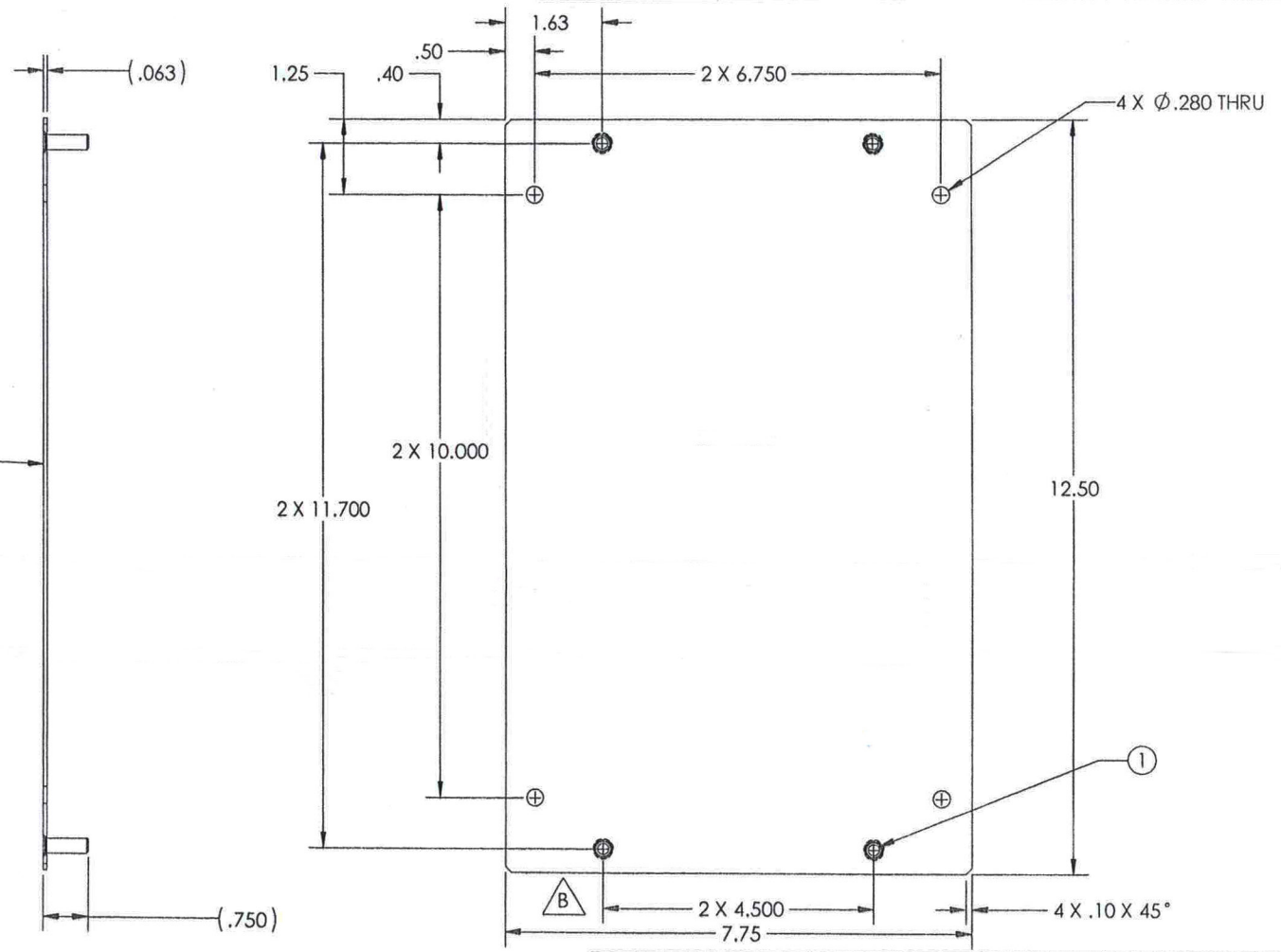
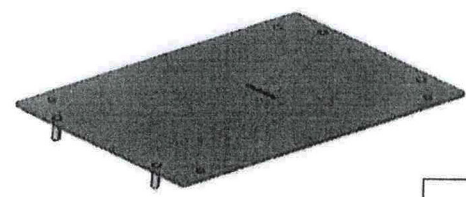

DCN		REV	REVISIONS	DATE	APPROVED
106974		A	INITIAL RELEASE	3/30/2016	JWF
107124		B	REVISE STUD SPACING	10/12/2016	JWF

ITEM NUMBER	QUANTITY	DESCRIPTION	PART NUMBER
1	4	PEM STUD 1/4-20	FH-0420-12

SENS
STORED ENERGY SYSTEMS
1840 INDUSTRIAL CIRCLE
LONGMONT, CO 80501
303-478-7500
WWW.SENS-USA.COM

PROPRIETARY AND CONFIDENTIAL
THE INFORMATION CONTAINED IN THIS DRAWING IS THE SOLE PROPERTY OF STORED ENERGY SYSTEMS, LLC. ANY REPRODUCTION IN PART OR AS A WHOLE WITHOUT THE WRITTEN PERMISSION OF STORED ENERGY SYSTEMS, LLC, IS PROHIBITED.

UNLESS OTHERWISE SPECIFIED:
DIMENSIONS ARE IN INCHES
DEFAULT TOLERANCES:
ANGLES ± 1°
TWO PLACE DECIMAL ± .025
THREE PLACE DECIMAL ± .008
DO NOT SCALE DRAWING

NAME	DATE	DESCRIPTION
johnf	03/29/2016	PLATE, ADAPTOR, FC MNTG TO MG2
CHECKED		
THIRD ANGLE PROJECTION		
DIMENSIONS & TOLERANCES PER ASME Y14.5 - 2009		

SIZE **B** DOCUMENT NUMBER 97-21-02

REV **B**
SHEET 1 OF 1