

Specifications:

Sizes: 2", 3" and 4"

Connections: Female NPT, Flanged

Body Type: Globe, Angle

Temperature Range: -20° F to 200° F

Trim Characteristic: Quick Open, Modified %
 (Throttling)

Trim Type: Balanced Soft Seat, Unbalanced Metal
 Seat

Pressure Rating:

500 psi - 2" NPT

250 psi - 2" Flanged

250 psi - 3" & 4" Flanged & NPT

Actuator Sizes: No. 35 (35 in² area), No. 70 (70 in²
 area)

Input Signal Ranges: 3-15, 6-30

Application

The CV40 is a low pressure, full port, dump valve. It features balanced plug control trim with a quick opening characteristic and an adjustable topworks. The CV40's full port allows for high flow rates, and its soft seat design gives a consistent leak free shut off when the valve closes. The CV40 can be used for discharging liquid or gas from separators, treaters, knockouts or other vessels. Also available are the CV40U, which features an unbalanced metal plug and seat design, good for avoiding sand buildup, and the CV41, offering an open yoke configuration for the valve.

**CV40 Reverse
 Globe Body**



Figure 1.

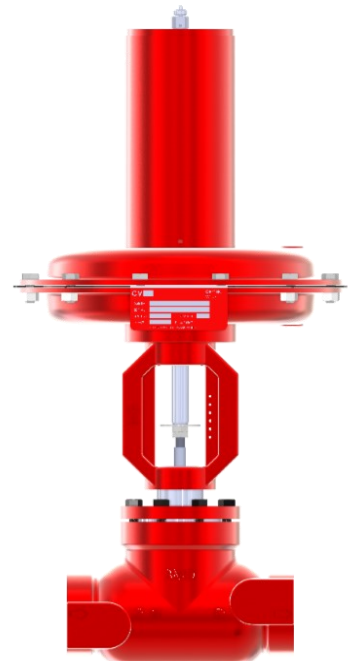

**CV41 Direct
 Globe Body**



Figure 2.

**CV40 Reverse
 Angle Body**

Model CV40 Installation

Installation

Before installing the CV40 make sure the threads are not damaged and are clear of any debris. Thread in a 1/4" NPT fitting into the actuator (Upper housing for direct, lower housing for reverse). Connect an instrument that provides a pneumatic signal to the CV40

Actuator Action

When connecting a pneumatic signal it is important to understand the differences between a reverse and direct acting actuator. If it's reverse acting (fail close) the signal needs to be connected to the port in the lower housing. For a direct acting (fail open) the signal needs to be connected to the port in the upper housing. See figure 4.

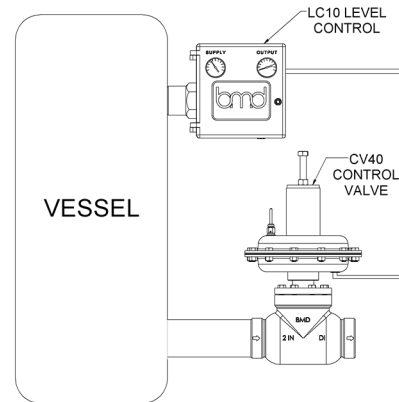

Figure 3. Typical Installation of CV40 w/ LC10 Level Controller

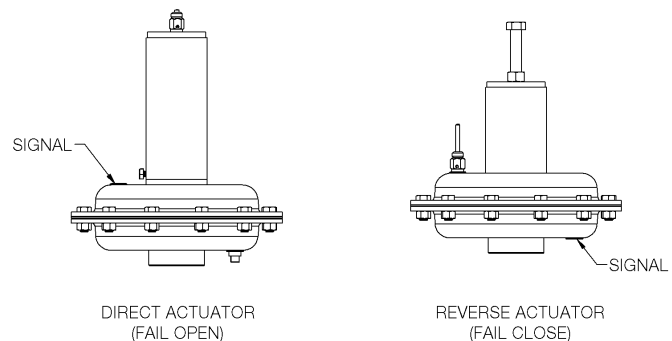

Figure 4.

Model CV40 Operation

Operation

The CV40 operates by receiving a pneumatic signal that, depending on the action of the actuator, will open or close the valve. For Reverse acting, as shown in figure 4, the pneumatic signal enters in the lower housing. The pressure builds and overcomes the spring force allowing the plug to lift off the seat. For Direct acting, as shown in figure 4, the pneumatic signal enters into the upper housing. The pressure builds and overcomes the spring force causing the plug to lower onto the seat.

Valve Adjustment

To adjust a valve with a reverse acting actuator loosen the adjusting screw nut and turn the adjusting screw CW to increase the seat load and CCW to decrease the seat load using a 3/4" wrench. The CV40 is a balanced trim valve so increasing the seat load will not affect how much pressure the valve will shut off against. However, a certain amount of seat load is required to make the valve seal initially. Increasing the seat load will also require a higher actuation pressure. For a direct acting actuator the seat load will be increased by increasing the signal pressure to the valve actuator.

Maintenance:

Trim Replacement—Soft Seat

Before changing the Trim, make sure the CV40 is closed off from service and completely depressurized. Loosen and remove the Bolts holding on the Bonnet Flange using a 9/16" wrench. Remove the Topworks Assembly by pulling straight up on the Actuator Housing. Remove the Seat using the Seat Removal Tool, see Table 6., and replace the seat O-ring. Once the new O-ring is in place, the Seat can be reinserted. Be sure the Seat is threaded in properly and use the Seat Removal Tool to tighten it down. Unscrew the Jam Nut to remove the Lock Washer and Plug Tip. Use a 1/4" wrench to hold the Stem in place while unscrewing the Jam Nut with a 9/16" wrench to prevent the stem from spinning. Replace the Seat Ring. Next, remove the Plug Body from the Bonnet. If the Plug Body is too difficult to remove, tighten down the Adjusting Bolt until it bottoms out. This will push the Plug Body out of the Bonnet some of the way. Make sure to mark on the Adjusting Bolt where it was set to ensure it is reset in the right position. Using a dry towel or rag, grab the Plug Body and twist as you pull to remove it from the Bonnet. Replace the Quad Ring and two Backup Rings. To reinstall the Plug Body, make sure the two Backup Rings are pressed in all the way around before forcing the Plug Body back into the Bonnet to avoid damaging the Backup Rings. Install the Plug Tip with a new Lock Washer and Jam Nut. Insert the Topworks Assembly into the body and bolt down the bonnet flange.

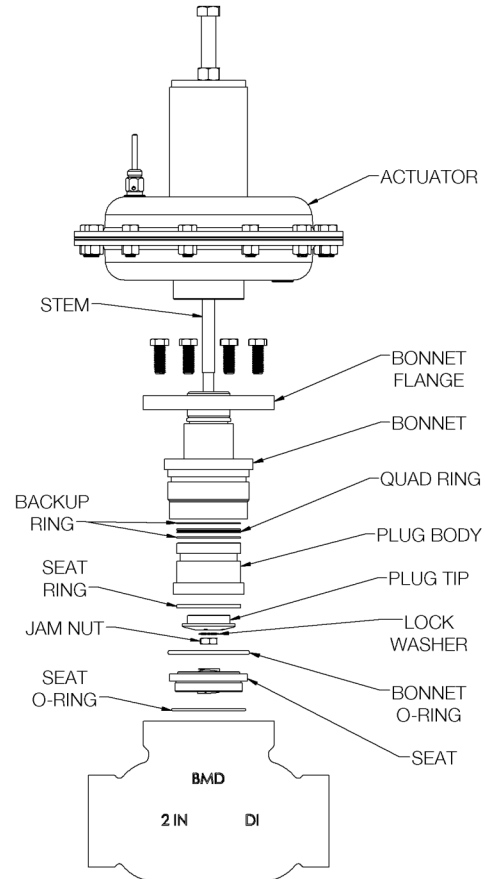

Figure 5.

Table 1.

CV40U TRIM REPAIR KITS		
SIZE	TRIM SIZE	PART NO.
2"	1.75"	58-00-0450
	1.00"	58-00-0451

CV40U Trim Repair Kits Include Lapped Trim Set (Cage and Plug), Seat O-ring, Spring Pin, and Bonnet O-ring

Table 2.

CV40 TRIM REPAIR KITS		
SIZE	SEAT RING MATERIAL	PART NO.
2"	VITON	58-00-0328
	TEFLON	58-00-0329
3"	VITON	58-00-0332
	TEFLON	58-00-0333
4"	VITON	58-00-0334
	TEFLON	58-00-0335

CV40 Trim Repair Kits Include Seat O-ring, Seat Ring, Bonnet O-Ring, Quad Ring, Backup Rings, Lock Washer and Jam Nut.

Model CV40 Maintenance

Trim Replacement—Metal Seat

The CV40U offers an unbalanced trim with metal seat that will be replaced differently. The trim includes a Plug and Cage that have already been lapped together. Before changing the Trim, make sure the CV40 is closed off from service and completely depressurized. Loosen and remove the Bolts holding on the bonnet flange using a 9/16" wrench. Remove the Topworks Assembly by pulling straight up on the Actuator Housing. Pull the Cage straight up to remove it from the body and replace the Seat O-ring. Once the new O-ring is in place, the new Cage can be inserted. Use a 1/8" punch to remove the Pin from the Plug and unscrew the Plug to remove from the Stem. If the Pin cannot be reached, tighten down the Adjusting Bolt until it bottoms out. Make sure to mark on the Adjusting Bolt where it was set to ensure it is reset in the right position. This will push the Plug out of the bonnet some of the way and expose the Pin. Replace the Quad Ring and two Backup Rings. Insert the Topworks Assembly into the Body and bolt down the Bonnet Flange.

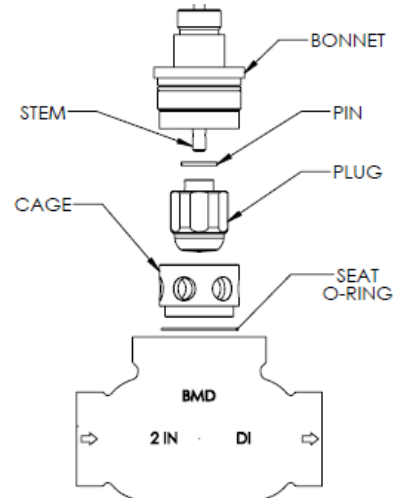

Figure 6.

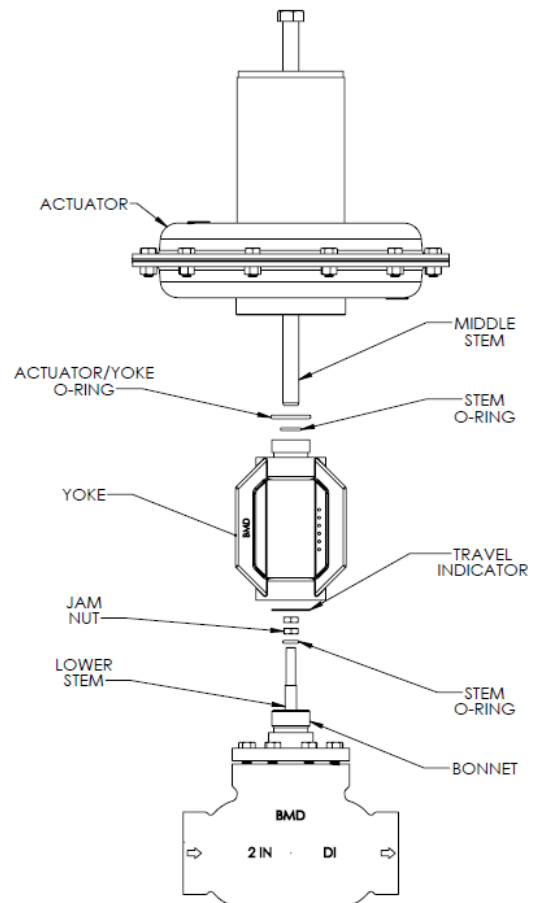

Table 3.

TRIM REPLACEMENT KITS			
SIZE	SEAT RING MATERIAL	FULL PORT	REDUCED PORT
2"	VITON	58-00-0465	58-00-0509
	TEFLON	58-00-0466	58-00-0510
3"	VITON	58-00-0484	58-00-0511
	TEFLON	58-00-0485	58-00-0512
4"	VITON	58-00-0486	58-00-0513
	TEFLON	58-00-0487	58-00-0514

Trim Replacement Kits Includes Plug Body, Plug Top, Plug Tip, Seat, and the Trim Repair Kit Parts except the Bonnet O-ring

Packing Replacement

Before replacing the packing, refer to the previous section and follow the instructions until the plug body is removed from the bonnet. Then, using the P.B.R.T. (packing bushing removal tool), partially unscrew the packing bushing to reduce friction on the stem. Unscrew the bonnet from the actuator and pull the two apart. The stem will stay be pulled away with the actuator. Remove the packing bushing using the P.B.R.T. and remove the stem packing, packing spring, and packing washer. The packing itself can either be pushed out from the top of the packing plug or pulled out with a pick tool. Before inserting the new packing be sure to grease each layer and be careful not to scratch the inside bore of the packing as this can cause the valve to leak. Also, be mindful about how the packing is inserted into the bonnet (See figure 8). Inspect the stem for damage as well since any grooves or scratches on it can cause leakage through the packing. Reinstall the packing bushing, without completely tightening, then reinsert the actuator back onto the bonnet. Finish tightening the packing bushing. Make sure the packing bushing is flush on the bonnet before moving forward. Reinstall the plug body into the bonnet then install the bonnet/ actuator assembly onto the body as detailed in the trim replacement section.

NOTE: BMD recommends greasing the packing set well with a PTFE based grease to enhance service life.

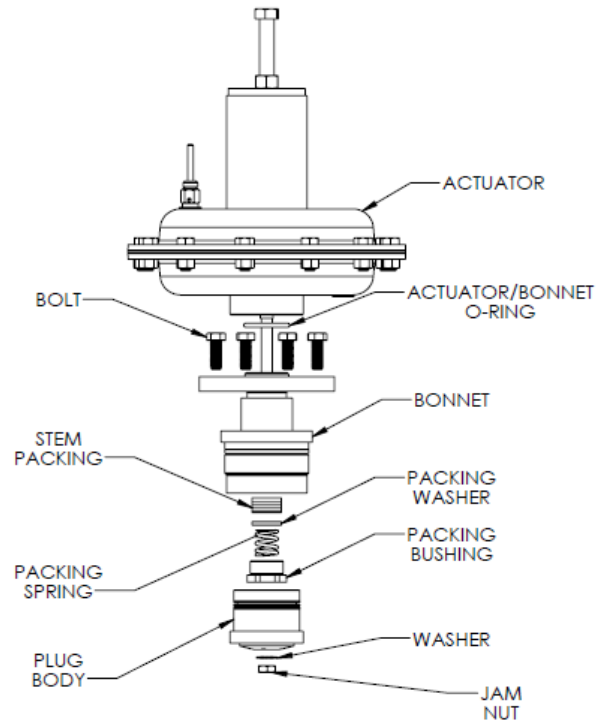

Figure 7.

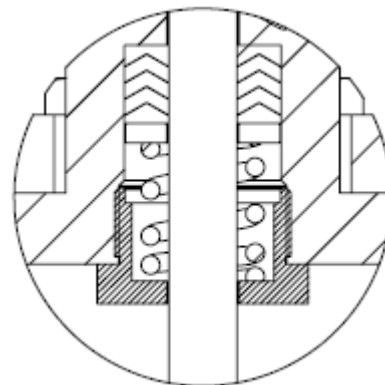

Figure 8.

Table 4.

PACKING REPAIR KIT	
ALL SIZES	58-00-0330

Packing Repair Kit Includes: Stem Packing, Packing Washer, Packing Spring, Packing Bushing, and Stem O-ring

Model CV40 Maintenance Cont.

Diaphragm Replacement

For a Reverse Acting Actuator loosen the Adjusting Screw until the Spring is no longer under pressure. For a Direct Acting Actuator remove the Spring Cover, and loosen the Hex Nut that is on top of the Upper Spring Retainer. Unscrew and remove all the Bolts holding the Upper and Lower Housing together. While holding the Hex Nut below the Diaphragm, remove the Jam Nut and Hex Nut from above the diaphragm. (On a direct acting actuator the Upper Stem will be removed instead of the upper Jam Nut and Hex Nut.) Remove the Lock Washer, Diaphragm O-ring, Diaphragm Plate, and Diaphragm. Install a new parts from the Diaphragm Repair Kit and reassemble the housing.

Table 5.

DIAPHRAGM REPAIR KITS	
SIZE	PART NO.
#35	58-00-0331
#70	58-00-0500

Actuator Repair Kits Include: Diaphragm, Diaphragm O-ring, Stem O-ring, Actuator/Bonnet O-ring, Upper Stem O-ring, Lock Washer, Hex Nuts, Jam Nuts, and Cotter Pin

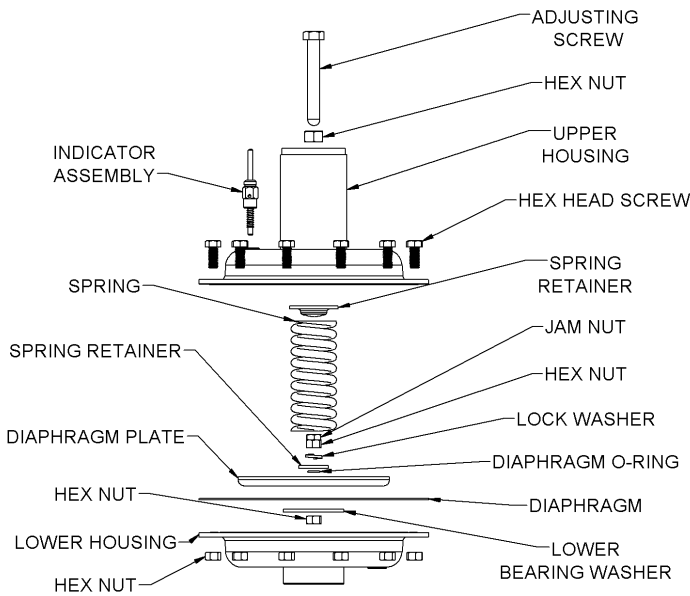

Figure 10.

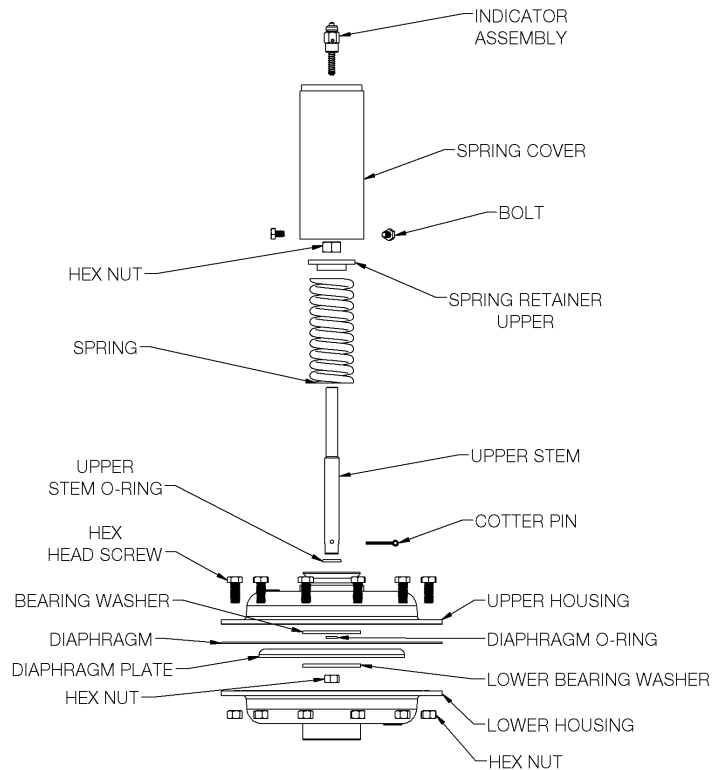

Figure 9.

Model CV40 Maintenance Cont.

COMPLETE TOPWORKS						
VALVE CONFIGURATION			#35 ACTUATOR 3-15 PSI SPRING	#35 ACTUATOR 6-30 PSI SPRING	#70 ACTUATOR 3-15 PSI SPRING	#70 ACTUATOR 6-30 PSI SPRING
CV40	2"	<i>REVERSE</i>	58-00-0362	58-00-0515	-	-
		<i>DIRECT</i>	58-00-0363	58-00-0516	-	-
	3"	<i>REVERSE</i>	58-00-0364	58-00-0517	58-00-0370	58-00-0523
		<i>DIRECT</i>	58-00-0365	58-00-0518	58-00-0371	58-00-0524
	4"	<i>REVERSE</i>	58-00-0366	58-00-0519	58-00-0372	58-00-0525
		<i>DIRECT</i>	58-00-0367	58-00-0520	58-00-0373	58-00-0526
CV40U	2"	<i>REVERSE</i>	58-00-0501	58-00-0456	-	-
		<i>DIRECT</i>	58-00-0502	58-00-0505	-	-
CV41	2"	<i>REVERSE</i>	58-00-0375	58-00-0527	58-00-0381	58-00-0533
		<i>DIRECT</i>	58-00-0376	58-00-0528	58-00-0382	58-00-0534
	3"	<i>REVERSE</i>	58-00-0377	58-00-0529	58-00-0383	58-00-0535
		<i>DIRECT</i>	58-00-0378	58-00-0530	58-00-0384	58-00-0536
	4"	<i>REVERSE</i>	58-00-0379	58-00-0531	58-00-0385	58-00-0537
		<i>DIRECT</i>	58-00-0380	58-00-0532	58-00-0386	58-00-0538
CV41U	2"	<i>REVERSE</i>	58-00-0508	58-00-0453	58-00-0454	58-00-0455
		<i>DIRECT</i>	58-00-0539	58-00-0540	58-00-0541	58-00-0542

CV40/CV41 Complete Topworks Include: Everything except the Body, Seat, Seat O-ring, Plug Top, Plug Body, Quad Ring, Backup Rings, Plug Tip, Lock Washer, Stem Nut.

CV40U/CV41U Complete Topworks Include: Everything except Body, Cage, Cage O-ring, Solid Plug
 #70 Actuator currently unavailable for 2" Valve Configurations

Table 6.

CV40 TOOLS	
Size	Part No.
2" SEAT	T114
3" SEAT	T115
4" SEAT	T116
P.B.R.T	T105
TOOL KIT	58-00-0358

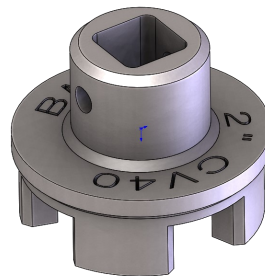

SEAT TOOL

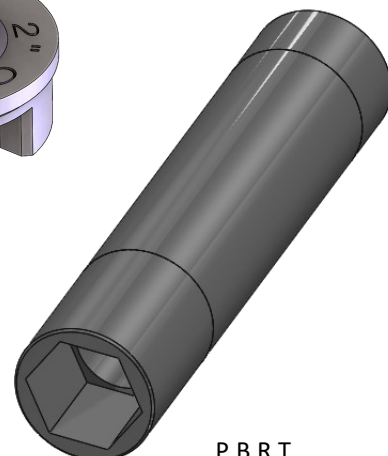

P.B.R.T.
 (PACKING BUSHING REMOVAL TOOL)

* Tool kit includes 2", 3" and 4" seat removal tools, packing bushing removal tool, o-ring pick, and CV10 cage pulling tool.

Model CV40 Maintenance Cont.

Table 8. Trouble Diagnosis

Symptom	Probable Cause(s)	Corrective Action(s)
In the closed position, process fluid leaks from inlet to outlet port	Insufficient spring tension for reverse-acting (fail close) actuator	Increase spring tension and watch for the leak to stop
	Excessive spring tension on direct-acting (fail open) actuator	Reduce spring tension and watch for leak to stop
	Insufficient supply pressure to a direct acting actuator (fail open)	Increase signal pressure
	Trim is worn or damaged or failed seat/seat-to-body o-ring	Change the seat o-ring as detailed in the trim replacement section
	Failed plug body o-ring	Change o-ring
Process fluid leaks into lower diaphragm housing	Bonnet-to-valve stem packing and bonnet-to-valve stem o-ring failed. The valve stem may be worn or damaged. If you cannot see the leak outside of the pipe, the bonnet weep hole is plugged.	Disassemble the actuator and valve. Inspect the o-ring and the sealed surfaces of the bonnet and stem. The packing must have some installation fit interference with both. Replace worn component(s) as necessary. If the bonnet weep hole is plugged then clean it
Process fluid is leaking from the bonnet weep hole	The bonnet-to-valve stem packing failed and the valve stem may be worn or damaged	Disassemble the actuator and valve. Inspect bonnet and stem sealing surfaces. The packing must have some installation fit interference with both. Replace the worn component(s) as necessary.
Process fluid is leaking from between the bonnet flange and valve body	Bonnet-to-valve body o-ring failed	Remove the actuator assembly at the bonnet flange. Inspect the o-ring and sealing surfaces of the bonnet and valve. Replace the worn
In Reverse-acting (fail close) actuators only: Supply pressure leaks from around the bonnet or from the bonnet weep hole	The actuator-to-bonnet o-ring failed or the valve stem-to-bonnet o-ring failed	Disassemble the actuator and inspect the o-ring, bonnet and actuator stem sealing surfaces. Disassemble the actuator and valve and inspect the o-ring, bonnet and valve stem sealing surfaces. Replace any worn components.

Model CV40 Maintenance Cont.

Table 8. Trouble Diagnosis Cont.

Symptom	Probable Cause(s)	Corrective Action(s)
Direct-acting (fail-open) actuator only: Supply pressure leaks from around the base of the spring cover on top of the upper diaphragm housing	The actuator stem-to-upper diaphragm housing o-ring failed	Disassemble the actuator and inspect the o-ring, back-up ring and sealing surfaces of the stem and housing bore. Replace the worn components as necessary
Supply pressure is leaking from the diaphragm housing vent plug when the valve is not moving	The actuator diaphragm is punctured	Disassemble the actuator and replace the diaphragm and diaphragm-to-diaphragm plate o-ring
The valve will not open completely OR the valve will not close completely	The actuator spring has excessive tension or the supply pressure is too weak to override the spring (or both)	Decrease spring tension until the flow is achieved; increase the actuator supply pressure if required
The valve is fully closed and will not open	The supply pressure line is connected to the wrong side of the actuator or the reverse-acting (fail close) actuator spring is completely compressed resulting in the inability to lift the valve plug	Make sure the actuator's supply pressure source line is connected to the lower diaphragm housing. Then decrease the spring tension until valve is open far enough to allow full travel
	The direct-acting (fail open) actuator cannot vent supply pressure due to a non-relieving pressure source device	Replace the supply pressure source device with one that relieves pressure or install a 3-way vent valve at the actuator supply connection
	In a reverse-acting (fail close) actuator, the supply pressure may be the problem and in a direct-acting (fail open) actuator, the spring tension may be insufficient to open the valve plug	If you have a reverse-acting (fail close) actuator, increase the supply pressure. If you have a direct-acting (fail open) actuator, increase the spring tension. For both, an increase in supply pressure may be required to re-close the valve

Model CV40 Maintenance Cont.

Table 8. Trouble Diagnosis Cont.

Symptom	Probable Cause(s)	Corrective Action(s)
The valve will not close. It is stuck fully open.	In a reverse-acting (fail close) actuator, the supply pressure cannot be vented due to a non-relieving pressure source device	Replace the supply pressure source device with one that is able to relieve pressure, or install a 3-way vent valve at the actuator supply connection
	The supply pressure line is connected to the wrong side of the actuator. If it's a direct-acting (fail open) actuator, the spring may be fully compressed and unable to create valve plug movement	Make sure that the actuator supply pressure source line is connected to the upper diaphragm housing. Decrease the spring tension to the minimum necessary to achieve full opening at the operating conditions
The valve movement is sluggish or unusually slow.	There may be actuator seal leakage	Perform the correlating corrective action suggested
	The opening of the diaphragm housing vent plug is partially blocked	Remove the vent plug and unclog the opening
The valve movement is sluggish or unusually slow. (Continued)	If the valve is new, the actuator supply pressure volume may be too low. If the valve has been in use for a while, the volume has diminished over time due to clogged openings and/or filters in control devices/	Increase the supply pressure line size and/or install a volume booster. Clean the openings and clean/ replace the filters of the control devices according to the manufacturer's recommendations