

Wire side view

- 1x Connector : Deutsch Nr. DT04-6P
- 3x Gold Terminals : Deutsch Nr. 04602021631
- 2x Terminals : Deutsch Nr. 046020216141
- 1x Lock Plate : Deutsch Nr. W6P
- 1x Cavity Plug : Deutsch Nr. 114017

INCLUDED:
 WIRE HARNESS INTEGRATED INTERFACE
 PARTS N°: **PEHJ 0962 807 030**
 (807) = interface type
 (030) = length in cm
Not removable

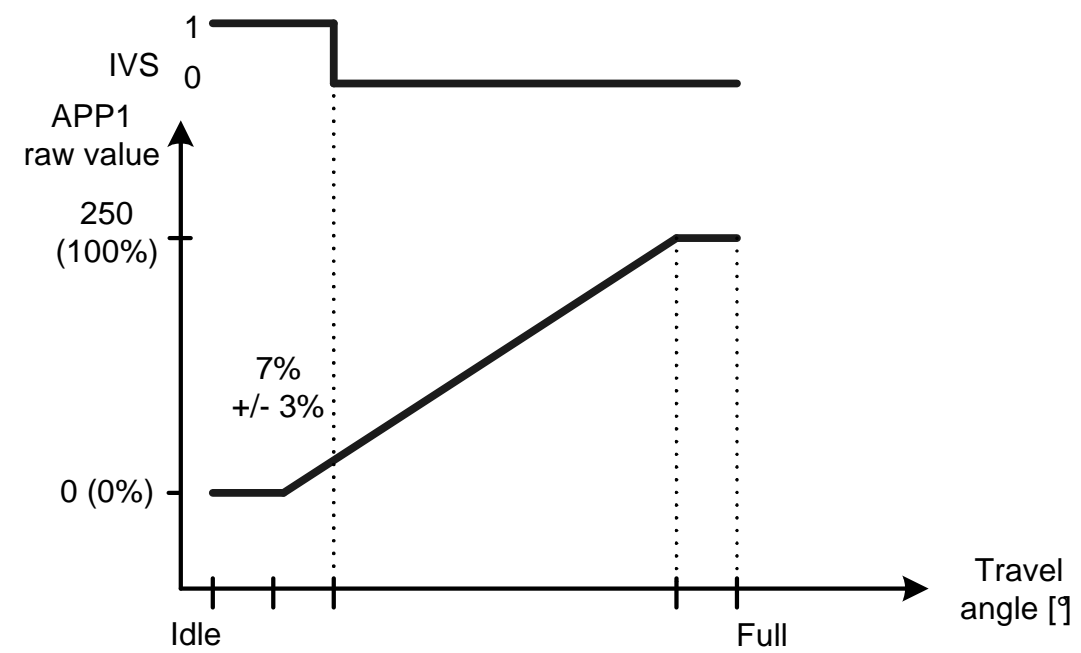

PIN N°	DESCRIPTION
1	SHIELD
2	CAN HIGH
3	CAN LOW
4	not connected
5	+8 .. 32VDC
6	0V GROUND

SETTING J1939		
BAUDRATE	250kb/s	
CYCLE TIME	50ms	
SOURCE ADDRESS	130 (82h)	
ID	OCF00382h	
EEC2	SPN91	0-100%
	SPN558	1-0
DTC	DM1	Enabled
	DM2	Enabled

N.A. = Not Activated or Not Applicable

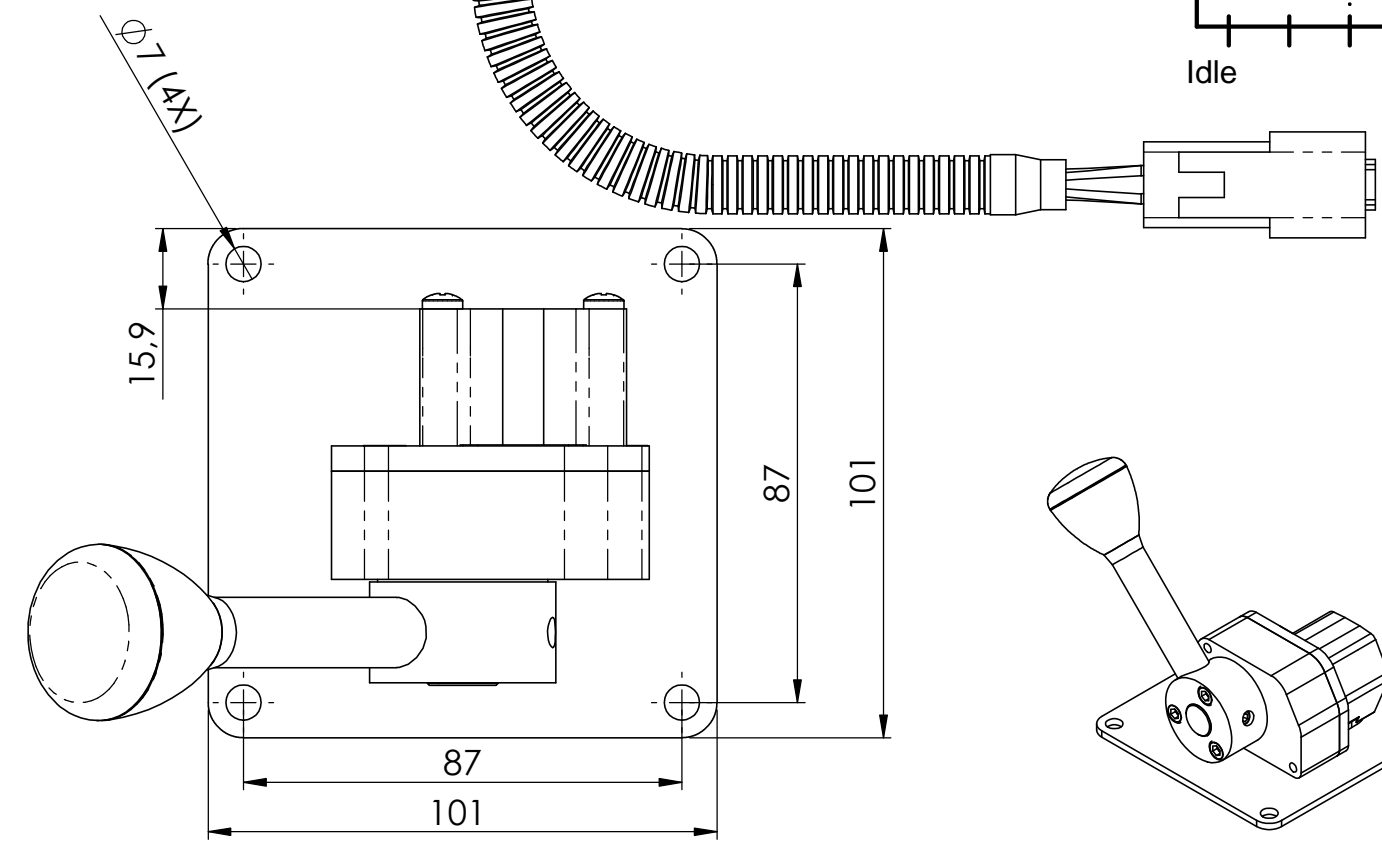

UNLESS OTHERWISE SPECIFIED: DIMENSIONS ARE IN MILLIMETERS TOLERANCES: LINEAR: +/- 1mm ANGULAR: +/- 1°		FINISH:	PROJECTION:	DO NOT SCALE DRAWING	SIZE: A3
DRAWN	JST	8/09/2022		PART NR: 972 890 28	
CHK'D	SB	8/09/2022		TITLE: Hand Throttle 90° CAN J1939	
MATERIAL:			DWG NO. 506 835		REV: -
This drawing is confidential and remains the sole property of Mobile Control Systems S.A. This document is protected in accordance with the prevailing law.			WEIGHT: - gr	SCALE:1:1.5	SHEET 1 OF 1